

**SAFETY AND  
OPERATION MANUAL  
ELECTRIC TUG™  
MODEL 898340A**

Part No. 841463 Rev. 2

## GENERAL INFORMATION



### IMPORTANT!

THIS MANUAL WILL AID YOU IN THE SAFE OPERATION AND PROPER MAINTENANCE OF YOUR EQUIPMENT. READ MANUAL THOROUGHLY BEFORE ATTEMPTING OPERATION. IF ANY PORTION IS NOT CLEARLY UNDERSTOOD, CONTACT AN AUTHORIZED DEALER FOR CLARIFICATION.

To make sure you are fully aware of safety and service information, the following two symbols are used throughout this manual.



This symbol is used throughout the manual to alert you to information about unsafe actions or situations, and will be followed by the word DANGER, WARNING, or CAUTION. DANGER indicates immediate hazards that may result in severe injury or death. WARNING indicates unsafe actions or situations that may cause severe injury, death and/or major equipment or property damage. CAUTION indicates unsafe actions or situations that may cause injury, and/or minor equipment or property damage.

### NOTICE

This symbol appears next to information or instructions which will help you operate and maintain your equipment properly.



### WARNING

- **The information and instructions included in this manual alert you to certain things you should do very carefully. If you do not, you could:**
  - injure yourself or others
  - injure the next person who operates the equipment
  - damage the equipment.
- **This manual contains essential operation and safety information and must remain with the unit at all times, within easy access of any operator.**

Additional manuals are available through your dealer.

## IMPORTANT!

THIS EQUIPMENT SHOULD NOT BE MODIFIED OR ADDED TO WITHOUT THE MANUFACTURER'S AUTHORIZATION.



### WARNING

- **Altering this equipment in any manner which adversely affects the equipments operation, performance, durability or use, may cause hazardous conditions.**

Direct any inquiries to:

Textron Turf Care and Specialty Products  
Attn: Chief Engineer, Product Engineering  
P.O. Box 82409  
Lincoln, NE 68501-2409 USA

## SPECIFICATION INFORMATION

All information contained in this manual is the latest available at the time of printing. Textron Turf Care and Specialty Products reserves the right to make changes at any time without notice.

Whenever a name brand product is specified, an equivalent product may be used unless stated otherwise.

## CHANGE OF OWNERSHIP OR ADDRESS

Textron Turf Care and Specialty Products makes every effort to keep owners informed of all safety related information. Therefore, changes in ownership and/or address should be reported to the manufacturer.

Your dealer has REGISTRATION CHANGE FORMS which will be filled out and filed by the dealer for his records, and a copy will be sent to the manufacturer.

## DEALER INFORMATION

For your nearest dealer location write to:

Textron Turf Care and Specialty Products  
Attn : Sales Coordinator  
P.O. Box 82409  
Lincoln, NE 68501-2409 USA

In the USA and Canada call 1-800-228-4444 (dealer information only).

# PICTORIAL DECALS

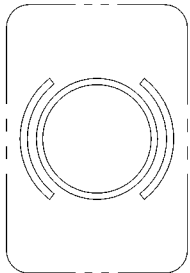

**Brake pedal**



**Parking Brake**



**Hour Meter**

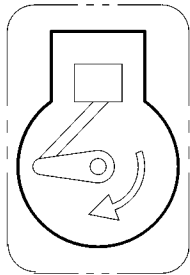

**Throttle pedal**



**Headlight**



**Off**



**Electrical Power**

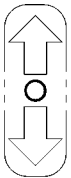

**Forward/Reverse Indicator**



**This decal indicates the unit is certified for use by the European community.**

## INDEX

	<b>Page</b>	
<b>A</b>		Serial Number, Vehicle . . . . . 3
Accessories . . . . .	5, 14	Service and Maintenance, Vehicle . . . . . 8
<b>B</b>		Service Publications . . . . . 3
Battery:		Specifications . . . . . 15
Charging . . . . .	10	Speed Control:
Condition Meter (Accessory) . . . . .	5	Controller . . . . . 11
Service . . . . .	10	Pedal . . . . . 5
Specifications . . . . .	10	Trouble Shooting Chart . . . . . 11-12
Belt Adjustment . . . . .	13	Standards and Publications . . . . . 2
Brake:		Storage . . . . . 14
Park . . . . .	5	<b>T</b>
Service . . . . .	5	Thermal Circuit Breaker . . . . . 7
Bulbs . . . . .	9	Tire Pressure . . . . . 13
<b>C</b>		Towing Capabilities . . . . . 8
Controls, Light, Meters, and Switches . . . . .	4	Towing the Vehicle . . . . . 8
<b>D</b>		Trouble Shooting Chart . . . . . 12
Decals, Pictorial . . . . .	1	<b>V</b>
Diagnostic & Trouble Shooting . . . . .	11	Vehicle Service & Maintenance . . . . . 8
Differential . . . . .	14	<b>W</b>
Direction Selector Switch . . . . .	4	Warranty, CUSHMAN . . . . . 17
Driving the Vehicle . . . . .	7	Warranty, Service . . . . . 16
<b>F</b>		Wiring Diagram, Vehicle . . . . . 18-21
Front and Rear Tire/Wheel Removal . . . . .	13	
<b>G</b>		
General Information . . . . .	Inside cover, 3	
<b>H</b>		
Horn Button and Handlebar . . . . .	4	
Hour Meter (Accessory) . . . . .	5	
<b>I</b>		
Identification, Vehicle . . . . .	3	
<b>J</b>		
Jacks and Jacking Locations . . . . .	14	
<b>K</b>		
Key Switch . . . . .	5	
<b>L</b>		
Light Switch . . . . .	5	
Lubrication:		
Chart . . . . .	9	
Guide . . . . .	9	
<b>M</b>		
Maintenance Guide . . . . .	9	
Model Number, Vehicle . . . . .	3	
Motor Brush Replacement . . . . .	10	
Motor Terminals . . . . .	10	
<b>O</b>		
Operation, Vehicle . . . . .	6	
Owner Registration . . . . .	Inside cover	
<b>P</b>		
Parking (Leaving) the Vehicle . . . . .	7	
<b>R</b>		
Rated Capacity . . . . .	7	
Rear Access . . . . .	10	
<b>S</b>		
Seat Adjustment Lever . . . . .	4	
Seat Switch . . . . .	5	

This unit is not a motor vehicle within the definition of the National Traffic Motor Vehicle Safety Act. It is not designed or manufactured for use on roads, streets, or highways. It is not appropriate for such use.

This unit is not meant to be licensed as a motor vehicle.

This is a Type "E" Electrical Vehicle. Type "E" Units are electrically powered units having minimum acceptable safeguards against inherent fire hazards. Users, operators and service persons should be familiar with the following standards and publications:

### STANDARDS AND PUBLICATIONS

The material may be obtained from the address shown.

- Factory Mutual Approval Standard: Class #7820; Electric battery Powered Trucks, Type E.  
ADDRESS: Factory Mutual Research Corp.  
1151 Boston-Providence Highway  
Norwood, Massachusetts, 02062
- National Fire Protection Association: ANSI/NFPA #505; Powered Industrial Trucks.  
ADDRESS: National Fire Protection Association,  
Batterymarch Park,  
Quincy, Massachusetts, 02269
- ANSI/ASME B56.8  
Personnel and Burden Carriers  
ADDRESS: American National Standards Institute,  
Inc.  
1430 Broadway  
New York, New York, 10018

- ANSI/UL 583; Electric Battery Powered Industrial Trucks.  
ADDRESS: American National Standards Institute, Inc.  
1430 Broadway  
New York, New York, 10018  
OR  
Underwriters Laboratories, Inc.  
333 Pfingsten Road  
Northbrook, Illinois, 60062

Cushman Electric Vehicles comply with ANSI B56.8 as it applies to OSHA for Powered Industrial Trucks under the Type E classification. The Electric Tug™ vehicle has been approved by Factory Mutual Research Corporation. To meet the manufacturer portions of the OSHA requirements (as stated in section 1910.178, Paragraph a3) Powered Industrial Trucks must bear the approval mark of either UL (Underwriters Laboratory) or FM (Factory Mutual) or other nationally recognized testing laboratories.

## SERVICE PUBLICATIONS

Additional operator's manuals and parts manuals are available for a minimum charge at this address:

Textron Turf Care and Specialty Products  
Attn. Service Dept.  
P.O. Box 82409  
Lincoln, Nebraska 68501 USA

## GENERAL INFORMATION

Your CUSHMAN Electric Tug™ Vehicle is powered by a 36 volt D.C. traction type motor. Three (3) heavy duty v-belts transmit the power to the differential.

A key type switch turns off the control system, preventing all electrical functions when the key is in vertical off position.

Standard equipment includes an electronic speed controller, handlebar steering, three (3) wheel hydraulic service brakes, hand operated parking brake, horn, stoplight, taillight, battery condition meter.

The range of this vehicle is up to 35 miles (56 km). Determining factors affecting the range are: battery condition and size, payload, the number of stops, tire pressure, acceleration and operating terrain.



### WARNING

- Altering this vehicle in any manner which adversely affects the vehicle's operation, performance, durability or use may cause hazardous conditions.

- NEVER attach ANY electrical device or accessory to this vehicle which is grounded to the vehicle frame.

## VEHICLE IDENTIFICATION

THESE IDENTIFICATION NUMBERS MUST APPEAR ON ALL CORRESPONDENCE CONCERNING THIS VEHICLE.

### MODEL NUMBER

The vehicle model number, model year and serial number are stamped on the decal attached to the left kick panel.

The complete ten (10) digit number is required to identify certain parts.

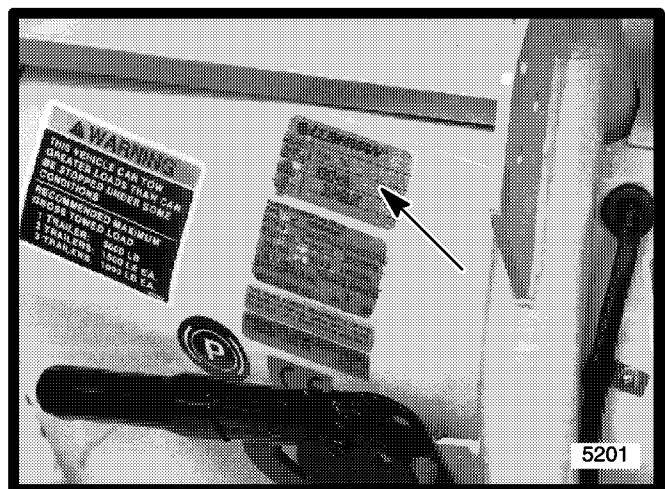

Model Number, Model Year and Serial Number on Decal

### VEHICLE SERIAL NUMBER

The vehicle serial number and model number is also stamped on the right wheel well under the deck.

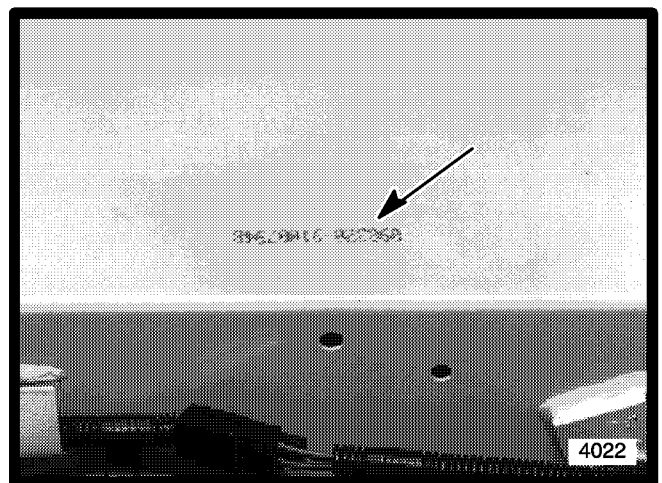

Serial Number and Model Number on Wheel Well

## CONTROLS, LIGHT, METERS AND SWITCHES

1. BATTERY CONDITION METER
2. KEY SWITCH
3. HEADLIGHT SWITCH
4. DIRECTION SELECTOR SWITCH
5. HORN BUTTON AND HANDLEBAR (NOT SHOWN)
6. SPEED CONTROL PEDAL
7. BRAKE PEDAL
8. PARKING BRAKE LEVER
9. MASTER CYLINDER CAP
10. HEADLIGHT (ACCESSORY) (NOT SHOWN)
11. HOUR METER (ACCESSORY)
12. QUICK DISCONNECT (EC MODEL ONLY)
13. TAIL LIGHT (NOT SHOWN)
14. BACKUP ALARM (NOT SHOWN)

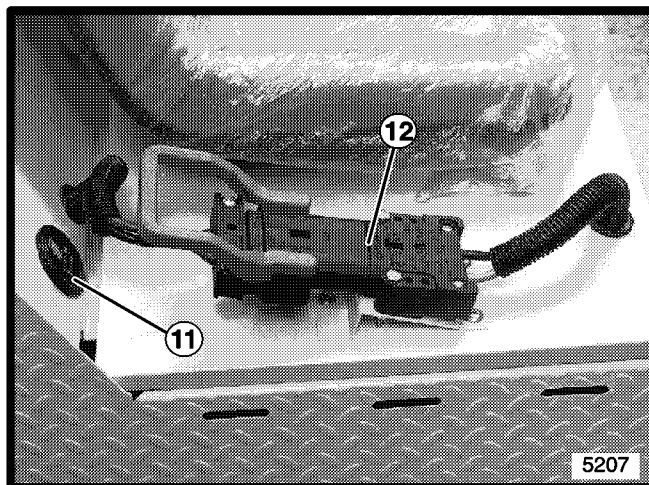
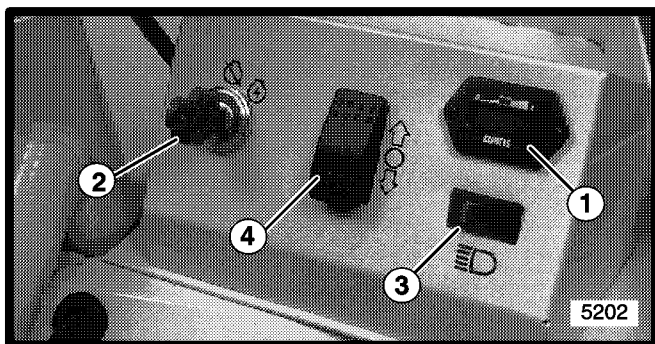

**SEAT ADJUSTMENT LEVER**

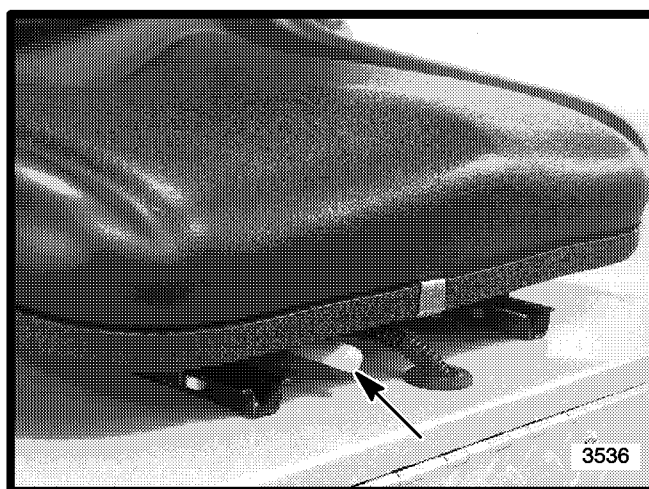

**Seat Adjustment Lever**

To adjust seat, move lever to the left side of the vehicle, and slide the seat to desired position, release lever.

### HORN BUTTON AND HANDLEBAR

The horn button switch is attached to the handlebar on the standard equipment vehicle.

A vehicle equipped with optional wheel type steering will have the horn button located in the center of the steering wheel.

Depress to sound horn. The horn will not sound when the key is in "OFF" position.

### DIRECTION SELECTOR SWITCH

The direction selector switch, located on the instrument panel, operates the contactors that control the direction of vehicle movement.

Depressing the top portion of the switch will select FORWARD direction, depressing the bottom of the switch will select REVERSE.

Backup alarm will sound when direction selector is placed in the reverse position.

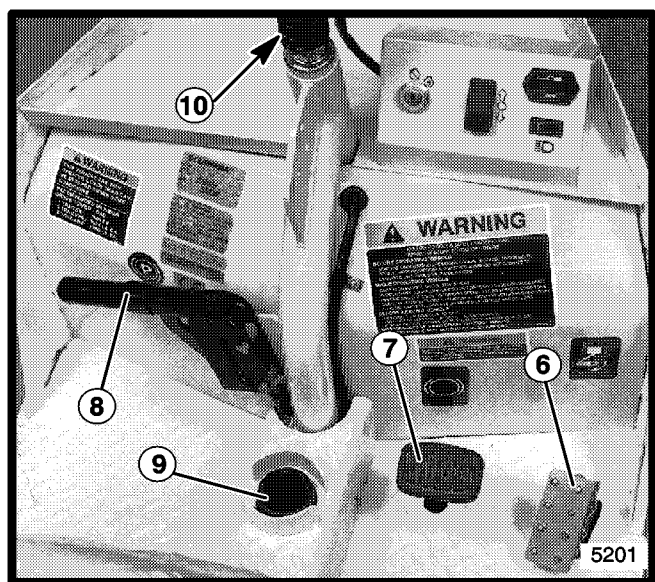

## KEY SWITCH

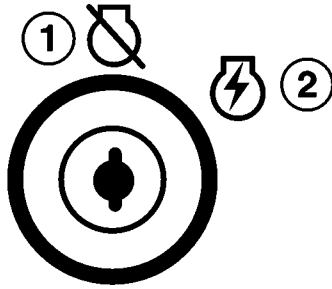

This is a two position switch:

1. OFF POSITION – Interrupts the vehicle’s electrical control system.
2. ON POSITION – Key is in this position for operation.

## BRAKE PEDAL AND PARKING BRAKE

Depress the brake pedal (push down) to slow or stop the vehicle.

Parking brake may be adjusted, by turning the end of the lever clockwise.

Pull the lever up to apply brake – push down to release.

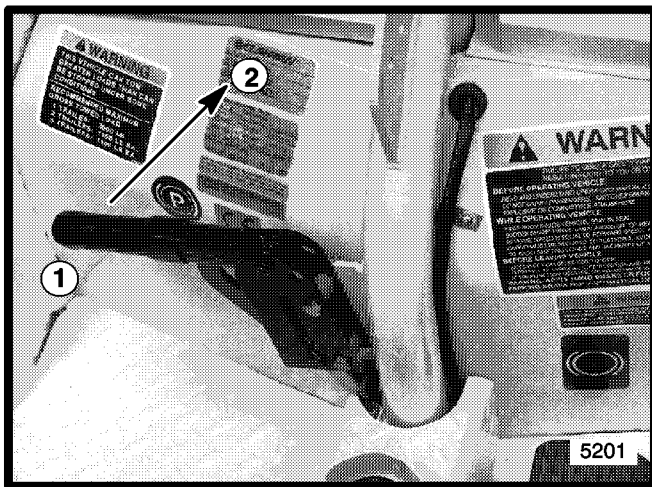

1. Parking Brake Released Position
2. Parking Brake Applied Position



## WARNING

- **ALWAYS** apply the parking brake whenever the vehicle is left unattended. The parking brake is **NOT** automatically applied.

## SEAT SWITCH

The seat switch, located under the operator’s seat, allows the speed controller to function only when the operator is properly seated.



## WARNING

- To prevent unexpected vehicle movement, **NEVER** operate the vehicle if the seat switch is **NOT** functioning properly.

## SPEED CONTROL PEDAL

This pedal is located on the floorboard. Operation with the pedal fully depressed gives maximum speed but is recommended only when the vehicle can be operated safely.

When slower speeds are desired, depress the pedal as required.



## WARNING

- To prevent loss of vehicle control, **NEVER** exceed safe operating speed. **ALWAYS** adjust speed to conditions.

## BATTERY “FUEL” GAUGE

A 10–bar LED display shows state of charge from full to empty.

At 70% discharge “ENERGY RESERVE” alert is signaled by a flashing light.

At 80% discharge a double flashing light indicates an “EMPTY CHARGE”.

## ACCESSORIES

### HEADLIGHT

The headlight can be pivoted on the mounting as required. Push switch to turn on or off.

### OUR METER

This meter records the number of hours the vehicle has been operated in a forward direction.

## OPERATION

The SAFETY WARNING decal is located on the upper portion of the right kick panel. All information on the decal is of the utmost importance. This decal and all others must remain on the vehicle.



- **Your safety and the safety of those around you depend on your care and good judgment in operating and maintaining this vehicle.**

**Read this section carefully and thoroughly in order to become familiar with proper operating procedures. Be sure to obtain an operating demonstration from your authorized Cushman dealer before attempting to drive the vehicle.**

**You, the operator, must take time to familiarize yourself with the function of all vehicle controls as well as the operating characteristics of the vehicle. This is best accomplished through careful application of proper operating procedures.**

- **This vehicle is heavy equipment that could cause serious injury or death to you the operator or bystanders if improperly used or overturned.**
- **NEVER operate this vehicle until the operator's manual is read and understood.**
- **ONLY trained and authorized persons shall operate this vehicle.**
- **NEVER allow children to operate the vehicle.**
- **The following steps tell you how to use this vehicle properly and what may happen if you do not.**

**1. BEFORE using the equipment, ALWAYS check all parts of the vehicle and any attachments. If something is wrong, STOP USING IT. Make sure**

**the problem is fixed before the equipment is used again.**

- 2. ALWAYS make sure the area of operation is clear of trash, litter and other objects.**
- 3. This vehicle is designed to carry ONLY YOU, the operator, in the seat provided by the manufacturer. NEVER carry any other persons on the vehicle.**
- 4. ALWAYS keep both hands on the handle bar whenever possible.**
- 5. ALWAYS use extreme care when backing and make sure no one is behind you. The reverse speed is half of forward speed. To maintain vehicle control, ALWAYS back the vehicle carefully at reasonable speed. Backup alarm will sound when direction selector is placed in the reverse position. DO NOT operate if backup alarm is not functioning properly.**
- 6. ALWAYS keep arms and legs inside of the vehicle while it is moving. Sit only in the seat provided by the manufacturer. Any body parts extending past the confines of the vehicle could be struck by nearby objects.**
- 7. NEVER use the vehicle in, or near, an area where there is explosive dust or fumes. The electrical system of this vehicle will make sparks which can ignite explosive materials.**
- 8. ALWAYS signal that you are going to turn or stop early enough so that other persons know that you plan to do so. Obey all traffic rules and regulations.**
- 9. ALWAYS watch for and avoid low overhang such as tree limbs, door jambs, overhead walkways, etc. Make sure there is enough room overhead for your vehicle and your head to clear easily.**
- 10. ALWAYS use good judgment when operating on or near an incline, ramp, grade, slope or other surface.**
- 11. ALWAYS adjust your speed to conditions(dry, moist, icy, etc.).**
- 12. NEVER start or stop suddenly. You may cause unstable vehicle operating conditions.**
- 13. NEVER change direction of vehicle abruptly or make sharp turns on an incline, ramp, grade, slope or other surface.**



14. **ALWAYS** stay a safe distance away from pedestrians, ramp edges, platforms, other equipment, etc.
15. **ALWAYS** drive straight up and down the face of an incline, ramp, grade or slope, **NEVER** across the face.

While driving down an incline, especially with a heavily loaded vehicle, **ALWAYS** remove the foot from the speed control switch pedal to avoid increasing the vehicle speed beyond level ground maximum speed. **ALWAYS** use foot brake to slow the vehicle.

**NEVER** park the vehicle with loaded trailers on incline or ramps.

**NEVER** leave the vehicle without applying the park brake and removing the switch key.

16. **NEVER** overload your vehicle, or trailers. The **MAXIMUM** rated capacity is: 450 lbs. (204 kg) includes 200 lbs. (91 kg) for operator; tows up to 5000 lbs. (2273 kg); up to 15000 (6804 kg) with additional trailer brakes. See towing capacities on page 8.

**ALWAYS** position loads carefully so they can't shift or tip over suddenly. Distribute loads evenly over rear area. **ALWAYS** keep loads low (not top heavy) so vehicle does not get top heavy when driven.

17. **ALWAYS** slow down when turning the vehicle with trailers.
18. **ALWAYS** allow sufficient space when turning corners with trailers.

## DRIVING THE VEHICLE

1. You, the operator, must be properly seated on the vehicle seat.
2. Insert key in switch, turn to ON position.
3. Position the direction selector switch for direction of vehicle movement desired.
4. Release the parking brake.
5. Slowly depress the speed control pedal to achieve the desired vehicle speed.

While driving down an incline, release the speed control switch pedal to conserve battery power and avoid increasing the vehicle speed beyond level ground maximum speed. Use foot brake to slow the vehicle.

### NOTICE

- To avoid motor damage, do not cause the motor to exceed normal operating speed.
- The vehicle electrical circuit includes a protective component.

#### THERMAL CIRCUIT BREAKER

This switch prevents overloading of the drive motor. Should the vehicle be stopped by the opening of the circuit breaker, the breaker will automatically reset in about 20 seconds. An audible click will be heard when circuit breaker resets. If the circuit breaker continues to open, a problem exists within the circuit, or vehicle is overloaded. Do not operate the vehicle.

Consult your authorized CUSHMAN Dealer for any service required.



### WARNING

- If the circuit breaker should open while driving on an incline, immediately apply the foot and parking brake to prevent loss of vehicle control.

## PARKING (LEAVING) THE VEHICLE

BEFORE you leave the operator's seat, do the following:



### WARNING

- **ALWAYS** apply/set the parking brake.
- **ALWAYS** place the direction selector switch in "OFF" (center) position.
- **ALWAYS** turn the switch key to vertical "OFF" position and remove the key to prevent unauthorized people from operating the vehicle.

When parking the vehicle only on an incline, the front wheel should be curbed whenever possible. See illustration.

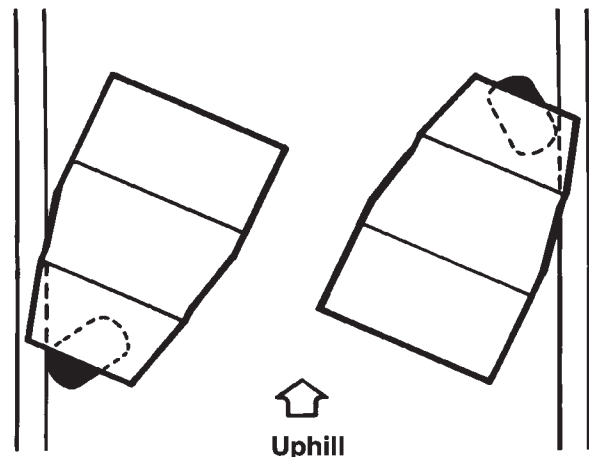

## TOWING THE VEHICLE

Attach towing equipment to the front kick panel outer edges near the floorboard.

Refer to the chassis lubrication chart for towing equipment attaching locations (page 9).



### WARNING

- **ALWAYS** attach towing equipment to the vehicle at the towing points. **NEVER** attach towing equipment under the vehicle. You may damage steering, brake lines, or other parts.
- **ALWAYS** remove the load before towing the vehicle. Towing a loaded vehicle could cause either vehicle to lose proper steering control.
- **NEVER** tow vehicle faster than 5 M.P.H. (8 km/h). Towing at excessive speed could cause either vehicle to lose proper steering control.

### NOTICE

- Towing the vehicle at excessive speed could cause damage to the drive train components, such as the drive motor which could cause the towed vehicle to stop abruptly.

## TOWING TRAILERS/ EQUIPMENT, ETC.



### WARNING

- Do not exceed 5,000 lbs. (2273 kg) gross weight towing capability of vehicle. Failure of brakes/steering may occur, injuring operator or bystanders.
- **NEVER** use the vehicle on floors, ramps or other surfaces that are NOT strong enough to support the vehicle when loaded with **MAXIMUM RATED PAYLOAD AND ANY TOWED TRAILER WITH PAYLOAD.**
- To prevent possible loss of control and collision or vehicle upset when towing, the operator must determine that the vehicle has adequate braking capacity to stop either a loaded or unloaded vehicle and the towed unit(s) on the type(s) of surface(s) and grade(s) on which the units will be operated. Sudden stops may cause trailers and vehicle to jackknife.  
**Also, the load must be positioned on the towed unit(s) so the trailer tongue weight on the vehicle will not cause instability or loss of vehicle steering control.**

### NOTICE

- Coasting the vehicle at excessive speed could cause damage to the drive train components, such as the drive motor which could cause the vehicle to stop abruptly.



### WARNING

- **This vehicle can tow heavier loads than can be stopped under some conditions.**

### RECOMMENDED MAXIMUM GROSS TOWED LOAD

- 1 Trailer: 5000 lbs. (2273 kg)
- 2 Trailers: 2500 lbs. (1136 kg)
- 3 Trailers: 1667 lbs. each (785 kg)

### NOTICE

- Towing a load greater than 5000 lbs. (2273 kg) up to 2500 lbs. (1136 kg) requires additional trailer brakes.

## VEHICLE SERVICE AND MAINTENANCE



### WARNING

- **When replacement parts are required, use genuine CUSHMAN parts. Failure to do so may result in product malfunction and possible injury to the operator and/or bystanders.**

**NEVER** attempt to perform service or maintenance functions on this vehicle if you are UNTRAINED or UNAUTHORIZED. Improper maintenance can cause hazardous conditions. See your authorized CUSHMAN dealer for necessary maintenance and service.

When it is necessary to raise the vehicle for any repair or service, use jackstands to provide adequate support. Do not rely on hydraulic or mechanical jacks.

It is advisable that your vehicle be equipped with an hour meter (set #884737) to record hours of operation. A good maintenance schedule can then be established.

The following maintenance guide provides a check list for servicing your vehicle. The guide is set up for average use on clean, paved surfaces. Vehicles used in dusty areas, or operated in mud, snow or water or for winter driving require more frequent service.

# MAINTENANCE GUIDE

## AS REQUIRED

Check tire pressure.  
 Fill batteries to proper level and check specific gravity.  
 Wash battery tops free of dirt and electrolyte.  
 Remove and clean corroded wire terminals, battery terminals and batteries. Reinstall wire terminals.  
 Use metal parts protector (Part No. 841192) to cover all electrical connections and battery terminals.

## NOTICE

- Be sure to make all connections prior to using the metal parts protector since it will coat all open surfaces.

## EVERY 200 HOURS

**Perform previous services**  
 Lubricate chassis\*  
 Check differential lube level (EP)  
 Check master cylinder fluid level – use DOT 3 brake fluid

## EVERY 1000 HOURS OR YEARLY

**Perform previous services**  
 Change differential lube (EP)  
 Clean and repack front wheel bearings (PG)  
 Check motor brushes

## LUBRICATION CODE

**PG – Pressure gun grease (lithium base)**  
**EP – Extreme pressure lube**  
**SAE – 80–90 Multigrade**  
**BF – Brake fluid DOT (3)**

## CHASSIS LUBRICATION CHART

Perform every 200 hours

LUBRICATION AREA	NUMBER OF LUBRICATION POINTS OR FITTINGS*
1. Brake pedal pivot crank	1
2. Fork tube upper bushing & lower bearing	2
3. Fork pivot bushing	2

\* Use a lithium base pressure gun grease on all grease fittings and lubrication points.

## CHASSIS LUBRICATION GUIDE

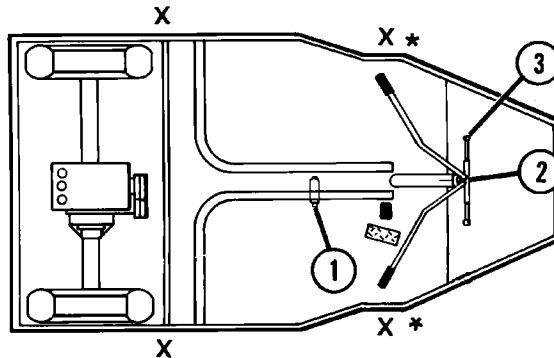

### IMPORTANT

\* TOW LINE ATTACHING POINTS

X JACKING LOCATIONS

## BULBS

Description	Specification or	Trade No.	Cushman No.
<b>BULBS</b>			
Headlight (accessory)	35 Watt (3000 CP)	No. 4411	820594
Light, Stop, Tail	32–4 CP	No. 1157 or No. 2057	822049

# BATTERY SPECIFICATIONS, SERVICE AND CHARGING

## SPECIFICATIONS

This vehicle requires six (6) deep cycle 6 volt batteries each with a MINIMUM capacity of 180 A.H. (ampere-hours at the SAE 20-hour rate) and 5/16" (8 mm) stud posts.

The MAXIMUM case dimensions are:

- Length ..... 10 3/8" (264 mm)
- Width ..... 7 3/16" (183 mm)
- Height ..... 11 5/8" (295 mm)  
(including posts)

## SERVICE AND CHARGING

### NOTICE

- DO NOT attempt to recharge the batteries with a charger not designed for this vehicle.



### WARNING

- UNTRAINED/UNAUTHORIZED persons should NEVER attempt to service or recharge the batteries of this vehicle.
- To avoid injury, use an adequate lifting device to lift the batteries and/or accessory lift out battery rack.
- NEVER use metal chains, etc., to lift the batteries and/or accessory lift out battery rack. They can cause electrical arcing resulting in battery explosion.
- Stay clear when lifting, lowering or moving the batteries and/or accessory lift out battery rack.

See your authorized CUSHMAN dealer for information about lifting devices.

## BATTERY LOCATION

The batteries are located under the seat deck.

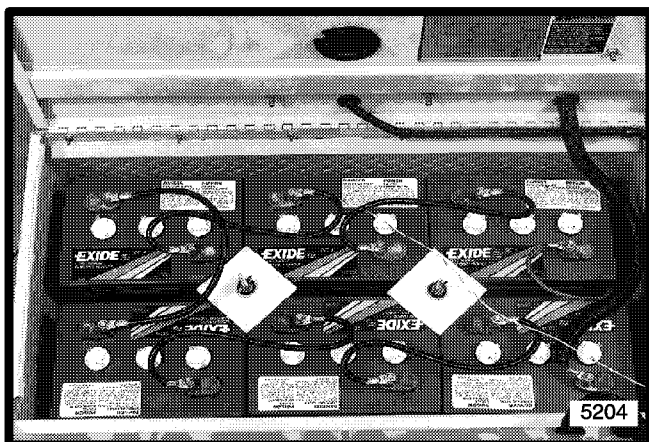

Standard Battery Arrangement

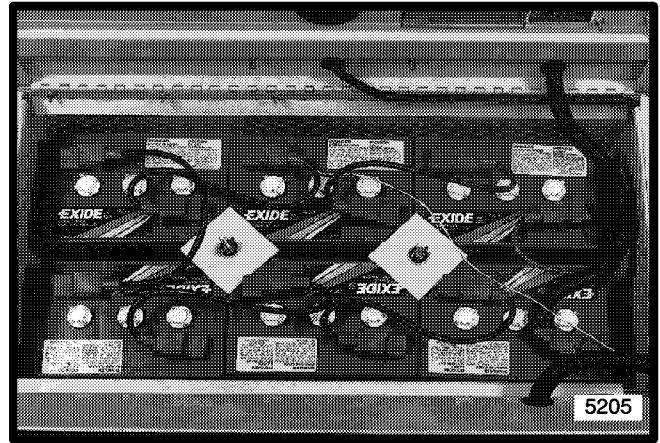

EC Battery Arrangement

## ACCESSORY LIFT OUT BATTERY RACK

The batteries and rack weigh approximately 400 lbs. (183 kg). Use an adequate lifting device to lift batteries.

## BATTERY CHARGER

The standard vehicle is equipped with a built in 36 volt, 25 amp DC, 120 volt AC, 60 HZ, fully automatic charger located under the vehicle seat. The battery charger will shut off automatically. If the battery condition meter indicates a full charge has not been achieved, check batteries and/or charger. Battery condition meter is reset to indicate a full charge at the end of charge cycle.

## REAR ACCESS

The cargo area floor may be removed to service the brakes, differential, drive motor and belts.



### WARNING

- The cargo area floor is a machinery guard and its removal exposes the operator to moving parts. Keep hands, hair and clothing away from belts and pulleys.

## MOTOR BRUSH REPLACEMENT

At regular maintenance intervals, each motor brush should be checked to determine if excessive wear or damage is evident. If a brush is broken, cracked, chipped or worn to a length of less than 5/8" (15.9 mm), measured on the short side of the brush, all brushes should be replaced. NEVER replace a single brush.

See your authorized Cushman dealer for service required.

## MOTOR TERMINALS

Motor wire to motor terminal connections should be clean and tight for maximum motor efficiency. Use metal parts protector spray (Part No. 841192).

### NOTICE

- Motor terminals should not be turned from original position.  
Hold terminal stud nut while torquing the wire terminal retaining nuts 50 to 70 in.-lbs. (5.5 to 8 N·m).

## SPEED CONTROLLER

The vehicle is equipped with an electronic speed controller that does not require servicing.

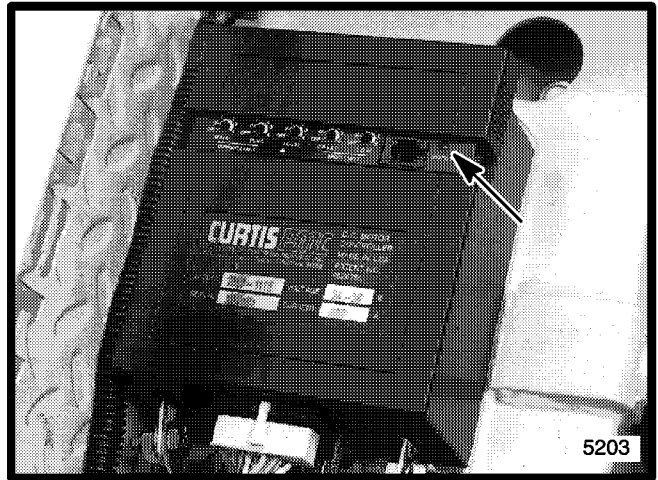

Controller LED Status Indicator

## DIAGNOSTICS AND TROUBLESHOOTING

### LED DIAGNOSTICS

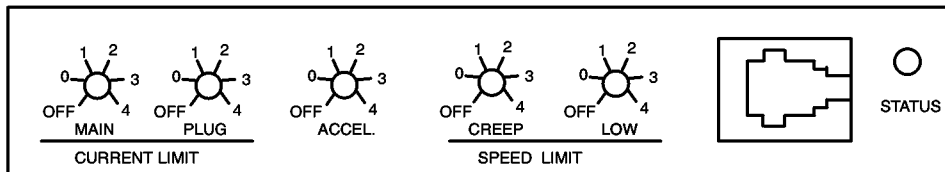

During normal operation, with no faults present, the Status LED flashes a single flash at approximately 1 flash/second. If the controller detects a fault, a 2-digit code (see Table) is flashed continuously until the fault is corrected. For example, code “3,2” –welded direction contactor – appears as:

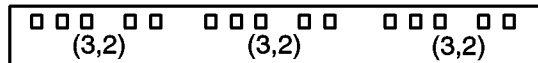

### PROGRAMMER ACCESSORY

A Controller Programmer is available, Part No. 893052

## TROUBLESHOOTING CHART

LED CODE	PROGRAMMER LCD DISPLAY	EXPLANATION	POSSIBLE CAUSE
1,2	HW FAILSAFE	hardware fail-safe error	1. Controller defective.
1,3	M-FAULT	M-output shorted	1. M-output shorted to ground. 2. Direction contactor not closing. 3. Direction contactor not closing fast enough. 4. Internal motor short to ground.
1,4	SRO	SRO fault	1. Improper sequence of KSI, brake and direction inputs. 2. Wrong SRO type selected. 3. Brake or direction switch circuit open. 4. Sequencing delay too short.
2,1	THROTTLE FAULT 1	5kΩ-0 or wiper fault	1. Throttle input wire open. 2. Throttle input wire shorted to ground or B+. 3. Throttle pot defective. 4. Wrong throttle type selected.
2,2	BB WIRING CHECK	emer. reverse wiring fault	1. BB wire open. 2. BB check wire open.
2,3	HPD	HPD sequencing fault	1. Improper seq. of KSI, brake, throttle inputs. 2. Wrong HPD type selected. 3. Misadjusted throttle pot.
2,4	THROTTLE FAULT 2	Pot Low broken or shorted	1. Pot Low wire open. 2. Pot Low wire shorted. 3. Wrong throttle type selected.
3,1	CONT DRVR OC	driver output overcurrent	1. Direction contactor coil shorted. 2. Shunt field shorted.
3,2	DIR CONT WELDED	welded direction contactor	1. Direction contactor stuck closed.
3,4	MISSING CONTACTOR	missing contactor or shunt	1. Direction contactor coil open. 2. Direction contactor missing. 3. Shunt field open. 4. Wire to shunt or direction contactor open.
4,1	LOW BATTERY VOLTAGE	low battery voltage	1. Battery voltage <16 volts. 2. Corroded battery terminal. 3. Loose battery or controller terminal.
4,2	OVERVOLTAGE	overvoltage	1. Battery voltage >45 volts. 2. Vehicle operating with charger attached.
4,3	THERMAL CUTBACK	over/under-temp. cutback	1. Temperature >85°C or <-25 °C. 2. Excessive load on vehicle. 3. Improper mounting of controller. 4. Operation in extreme environments.

### BELT ADJUSTMENT

The motor mount assembly pivots to provide belt adjustment. Turn the adjusting nuts as required. When properly adjusted, the belts will be tight enough to prevent slippage. Do not overtighten.

The motor base is slotted to allow the motor to be moved on the mounting plate, should the pulleys become misaligned.

The belts should always be replaced in matched sets of three.

#### NOTICE

- To avoid unnecessary belt wear and load on the motor, do not overtighten the belts or operate with misaligned pulleys.

### FRONT TIRE REMOVAL



#### WARNING

- When it is necessary to raise the vehicle for any repair or service, use jackstands to provide adequate support. **DO NOT** rely on hydraulic or mechanical jacks.

Remove and reinstall as follows:

- Loosen the axle nuts and lower entire wheel, hub and axle assembly from front fork. Remove the four wheel retaining nuts.
- Reinstall tire and wheel by reversing above sequence and tighten wheel retaining and axle nuts to 70 to 100 ft. – lbs. (95 to 140 N·m) torque.
- Position the large flat washer located on ends of the axle, on the inside of the fork side arm assembly.

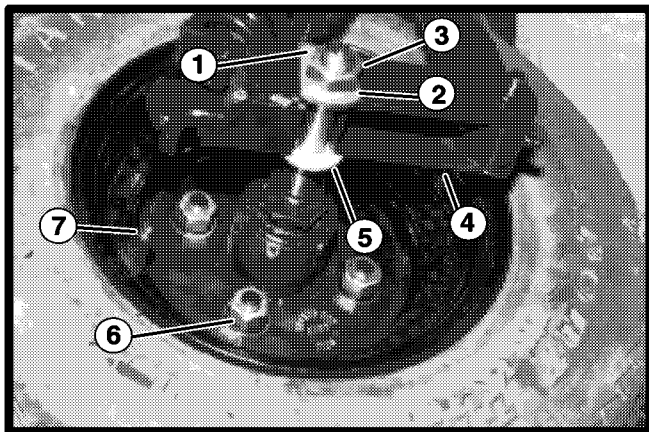

- |                    |                        |
|--------------------|------------------------|
| 1. Front axle lock | 5. Washer              |
| 2. Lockwasher      | 6. Wheel retaining nut |
| 3. Axle nut        | 7. Valve stem          |
| 4. Side arm        |                        |

#### NOTICE

- Install the wheel assembly with the valve stem on the right side.
- Make sure the fork side arm reaction pin is inserted in slot of the brake dust shield.

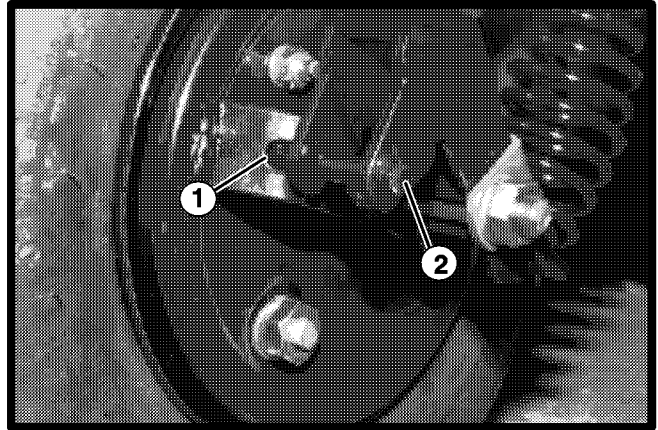

1. Dust Shield Slot
2. Reaction Pin



#### WARNING

- When reinstalling the front wheel assembly to the fork side arm, **ALWAYS** place the axle locks over the side arm (as shown) and tighten the axle nuts.  
**Failure to follow the procedure may allow the axle to drop out of the fork side arm and result in loss of vehicle control.**
- The fork side arm reaction pin **MUST** be inserted in the brake dust shield slot to prevent the shield from turning when the brakes are applied.

### REAR TIRE REMOVAL



#### WARNING

- When it is necessary to raise the vehicle for any repair or service, use jackstands to provide adequate support. **DO NOT** rely on hydraulic or mechanical jacks.

Remove and reinstall as follows:

- Remove the wheel retaining nuts and remove wheel assembly from hub.
- Reinstall the tire and wheel by reversing above sequence and tighten wheel retaining nuts to 70 to 75 ft.–lbs. (95 to 102 N·m) torque.
- Make sure the valve stem is located toward the outside.

## TIRE AIR PRESSURE

Tire Size	Maximum Cold Inflation Pressure
4.00 –4.80 x 8	60 PSI (414 kPa)

Fill tires with care. Use a pressure gauge before connecting an air hose to a partly inflated tire. Due to the low air volume needed, over-inflation may be reached in a matter of two or three seconds.

### NOTICE

- Proper inflation will improve the life of your tires considerably.
- NEVER exceed maximum air pressure indicated on tire.
- If the vehicle is operated on any surface other than smooth and level, the use of foam filled or solid tires could cause premature failure of tires, axles and suspension components.
- The tires are to be used on the welded one piece wheel only.
- Use replacement tires equivalent to or exceeding original equipment specifications.

## DIFFERENTIAL

The filler plug and the drain plug are illustrated. Check oil level frequently. It should always be up to the level of the filler hole.

### IMPORTANT!

DRAIN DIFFERENTIAL AFTER FIRST 100 HOURS OF SERVICE AND REFILL WITH EP80–90 MULTIGRADE EXTREME PRESSURE LUBRICANT. THEREAFTER LUBRICANT SHOULD BE CHANGED PER MAINTENANCE GUIDE.

REPAIRING THIS REAR AXLE IS A MAJOR SERVICE OPERATION AND SHOULD BE PERFORMED BY YOUR AUTHORIZED CUSHMAN DEALER WHO HAS THE NECESSARY EQUIPMENT AND INFORMATION.

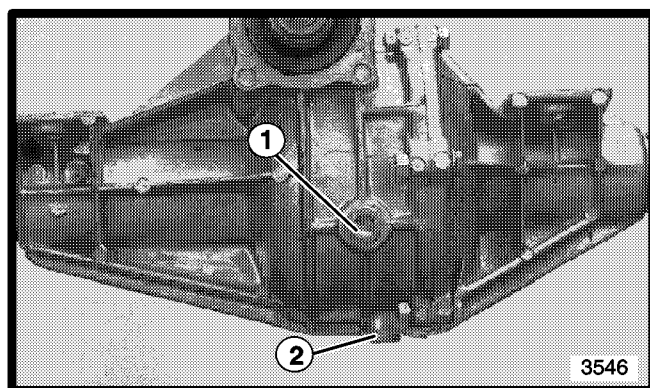

1. Filler Plug
2. Drain Plug

## JACKS AND JACKING LOCATIONS

A scissors type jack with a 1 1/2 ton (minimum) capacity is required. Use jackstands to support vehicle, do not rely on scissor, hydraulic or mechanical jacks.

The jacking locations are shown on the chassis lubrication chart illustration (page 9). Raise the vehicle ONLY enough to perform maintenance required.

## STORAGE

If the vehicle is to be stored, remove the connecting wires and batteries. Clean as required. Clean battery racks.

Battery electrolyte is an acidic solution and should be handled with care. If electrolyte is spilled or splashed on any part of the body, immediately flush the exposed area with liberal amounts of water and obtain medical aid immediately.

Reinstall the batteries and wires. Make sure the batteries are fully charged.

Check the state of charge of the batteries every 30 days and recharge as necessary to maintain the specific gravity above 1.230 (corrected for electrolyte temperature\*).

\*Hydrometer readings should be increased .004 for every 10 degrees F. (5.5°C) above 80 degrees F. (27°C) and decreased .004 for every 10 degrees F. (5.5°C) below 80 degrees F. (27°C).

### NOTICE

- Batteries should not be allowed to freeze. A cool dry storage area will help prevent self discharge.

## ACCESSORIES ARE AVAILABLE FOR USE ON THIS VEHICLE

Accessories include literature concerning installation, operation, and safety information about the accessory. Such literature should be kept with this manual for future reference.

Read and understand all literature before attempting to operate this vehicle or any attached equipment.



## SPECIFICATIONS

### STANDARD FEATURES

3-wheel; yellow; 16-gauge unitized diamond-pattern steel body with steel frame; carbon steel bumper with integrated rear hitch mounting area; 3-wheel hydraulic brakes; 225 amp hr batteries; battery condition meter/power "on" light; built-in Lestronic II automatic charger with anti drive-away relay; programmable electronic speed controller with SRO (Static Return to Off) capabilities; handlebar steering; rear shock absorber; combination stop/taillight; horn; reverse sounder.

### POWER

**Motor:** 36-volt, DC series; 3 hp (2.2 kW) at 3000 rpm; 7.6 hp (5.7 kW) at 800 rpm; 3 V-belt drive.

**Differential:** Worm gear reduction; aluminum housing; 15.67:1 axle ratio.

### PERFORMANCE

**Rated Capacity:** 450 lbs (204 kg) includes 200 lbs. (91 kg) for operator; tows up to 5000 lbs. (2273 kg); up to 15000 (6804 kg) with additional trailer brakes.

**Speed (maximum):** Up to 7.8 mph (12.55 km/h).

### SUSPENSION

**Front:** Heavy-duty coil springs.

**Rear:** Heavy-duty coil spring with shock absorber.

### BRAKES

**Service:** 3-wheel hydraulic.

**Parking:** Hand lever, operates on rear wheels.

### TIRES

4.80 x 8, load range B; optional solid or foam filled.

### DIMENSIONS

**Overall Height:** 37" (940 mm) to top of handlebar.

**Overall Length:** 76" (1.9 M) without hitch.

**Overall Width:** 34.5" (876 mm).

**Cargo Area:** 21" x 33.5: (533 mm x 851 mm).

**Weight:** 946 lbs. (429 kg) with batteries.

# TEXTRON TURF CARE AND SPECIALTY PRODUCTS WARRANTY

Textron Turf Care And Specialty Products warrants for one (1) year each new **Ransomes/Cushman/Ryan** unit and serialized accessories except for the Envirojet high pressure injection system components which are warranted for one (1) year or 200 hours whichever occurs first, according to the following terms:

This warranty extends to the original retail purchaser only and commences on the date of original retail purchase. Accordingly this warranty is not transferable to any subsequent purchasers.

Any part of the **Ransomes/Cushman/Ryan** unit or serialized accessory manufactured by Textron Turf Care And Specialty Products and found in the reasonable judgement of Textron Turf Care And Specialty Products to be defective in material or workmanship **will be repaired or replaced by** an authorized **Ransomes/Cushman/Ryan** dealer without charge for parts and labor.

The **Ransomes/Cushman/Ryan** unit or serialized accessory including any defective part must be returned to an authorized **Ransomes/Cushman/Ryan** dealer within the warranty period. The expense of returning the **Ransomes/Cushman/Ryan** unit or serialized accessory to an authorized dealer for warranty service and the expense of returning it back to the owner after repair or replacement will be paid for by the owner. Textron Turf Care And Specialty Products's responsibility in respect to claims is limited to making the required repairs or replacements, and no claim of breach of warranty shall be cause for cancellation or rescission of the contract of sale of any **Ransomes/Cushman/Ryan** unit or serialized accessory.

Proof of purchase will be required by the authorized **Ransomes/Cushman/Ryan** dealer to substantiate any warranty claim. All warranty work must be performed by an authorized **Ransomes/Cushman/Ryan** dealer.

Textron Turf Care And Specialty Products makes no warranty with respect to engines, tires, batteries, regulators, starter-generators, electric motors, or other parts not of their manufacture as such parts are usually warranted separately by their respective manufacturers.

This warranty does not include service items subject to normal wear, such as filters, spark plugs, ignition points, brake and clutch linings, belts, light bulbs, fuses, bearings, electrical contacts, etc.

This warranty does not cover any **Ransomes/Cushman/Ryan** unit or serialized accessory that has been subject to misuse, neglect, negligence, or accident, or that has been operated or maintained in any way contrary to the operating or maintenance instructions as specified in the **Ransomes/Cushman/Ryan** Operator's Manual. The warranty does not apply to any **Ransomes/Cushman/Ryan** unit or serialized accessory that has been altered or modified so as to adversely affect the units operation, performance or durability or that has been altered or modified so as to change its intended use. In addition, the warranty does not extend to repairs made necessary by normal wear, or by the use of parts or accessories which in the reasonable judgement of Textron Turf Care And Specialty Products are either incompatible with the **Ransomes/Cushman/Ryan** unit or adversely affect its operation, performance or durability.

Textron Turf Care And Specialty Products reserves the right to change or improve the design of any **Ransomes/Cushman/Ryan** unit or serialized accessory without assuming any obligation to modify any unit previously manufactured.

**ALL OTHER WARRANTIES OR CONDITIONS, EXPRESS OR IMPLIED, INCLUDING MERCHANTABILITY, FITNESS FOR A PARTICULAR PURPOSE OR OTHERWISE ARE EXPRESSLY EXCLUDED. THERE ARE NO WARRANTIES WHICH EXTEND BEYOND THE DESCRIPTION ON THE FACE HEREOF. ANY ACTION FOR BREACH OF WARRANTY MUST BE COMMENCED NO LATER THAN ONE YEAR FROM THE DATE OF DELIVERY.**

**TEXTRON TURF CARE AND SPECIALTY PRODUCTS'S OBLIGATION UNDER THIS WARRANTY IS STRICTLY AND EXCLUSIVELY LIMITED TO THE REPAIR OR REPLACEMENT OF DEFECTIVE PARTS, AND TEXTRON TURF CARE AND SPECIALTY PRODUCTS'S OBLIGATION DOES NOT ASSUME OR AUTHORIZE ANYONE TO ASSUME FOR THEM ANY OTHER OBLIGATION.**

**TEXTRON TURF CARE AND SPECIALTY PRODUCTS ASSUMES NO RESPONSIBILITY FOR INCIDENTAL, CONSEQUENTIAL OR OTHER DAMAGES INCLUDING, BUT NOT LIMITED TO, EXPENSE FOR GASOLINE, EXPENSE OF RETURNING THE RANSOMES/CUSHMAN/RUAN UNIT TO AN AUTHORIZED DEALER AND EXPENSE OF RETURNING IT BACK TO THE OWNER. MECHANIC'S TRAVEL TIME, TELEPHONE OR TELEGRAM CHARGES, TRAILERING OR TOWING CHARGES, RENTAL OF A LIKE UNIT DURING THE TIME WARRANTY SERVICE IS BEING PERFORMED, TRAVEL, LODGING, LOSS OR DAMAGE TO PERSONAL PROPERTY, LOSS OF REVENUE, LOSS OF USE OF UNIT, LOSS OF TIME OR INCONVENIENCE.**

This warranty gives you specific legal rights, and you may also have other rights which vary from state to state.

RANSOMES • CUSHMAN • RYAN  
P.O. BOX 82409  
Lincoln, Nebraska 68501-9971

# WARRANTY SERVICE

To make a claim under warranty, contact an authorized **Ransomes/Cushman/Ryan** dealer immediately upon realizing a problem exists. We recommend having the warranty work performed by the dealer who originally sold you the unit; however, warranty work can be sought from any authorized **Ransomes/Cushman/Ryan** dealer. Remember, your **Ransomes/Cushman/Ryan** unit must be delivered to an authorized **Ransomes/Cushman/Ryan** dealer within the warranty period, and all warranty work must be performed only by an authorized **Ransomes/Cushman/Ryan** dealer. Proof of purchase will be required by the dealer to substantiate any warranty claim.

## EXAMPLES OF ITEMS NOT COVERED UNDER WARRANTY

Provisions of the warranty will not apply to:

Normal service requirements arising during the warranty period, such as carburetor or ignition adjustment and cleaning or wear of a drive belt, brake, clutch linings or starter brushes.

Normal service work over and above the repair and replacement of defective parts.

Unit subject to misuse, neglect, negligence, or accident.

Units that have been altered or modified so as to adversely affect their operation, performance or durability or to change their intended use.

Repairs made necessary by the use of parts or accessories which are either incompatible with the unit or adversely affects the operation, performance or durability.

Units not operated or maintained in accordance with the instructions in the **Ransomes/Cushman/Ryan** Operator's Manual.

Normal cleaning, adjusting or replacing of such items as filter, spark plugs, ignition points, light bulbs, fuses or starter drive.

Periodic checking or adding of lubricant to the unit or service check-up, tune-up or diagnosis.

**Expense of delivering the unit to the dealer and expense of returning the unit back to the owner, mechanic's travel time, trailering or towing charges, or rental of a like unit during the time warranty repairs are being performed.**

**Engines, tires, batteries, regulators, starter-generators and electric motors manufactured by other than Textron Turf Care And Specialty Products are not covered under this warranty as such parts are usually warranted by their respective manufacturers.**

**This warranty applies only to the original retail purchaser. Second-owner or subsequently owned units are not covered under warranty.**

## OWNER'S OBLIGATION AND RESPONSIBILITY

Normal maintenance service and replacement of service items are the responsibility of the owner and as such are not considered defects in material or workmanship within the terms of the warranty. Individual operating habits and usage contribute to the need for maintenance service.

See your **Ransomes/Cushman/Ryan** dealer for proper maintenance and care of your unit. Proper maintenance and care will assist in keeping your overall operating cost at a minimum.

To validate a warranty claim, it is the owner's responsibility to maintain all components in proper adjustment and service the unit as specified in the **Ransomes/Cushman/Ryan** Operator's Manual. It is the owner's responsibility to provide proper lubrication for all components and to provide correct recommended fuel for the unit. It is the owner's responsibility to maintain the battery liquid level and charge as specified, as well as maintaining the correct pressure in the tires of this unit.

# WIRING DIAGRAM

W/BL	2
W/G	3
W/B	4
BL	5
W	6
Y	7
G	12
BR	14
R	16

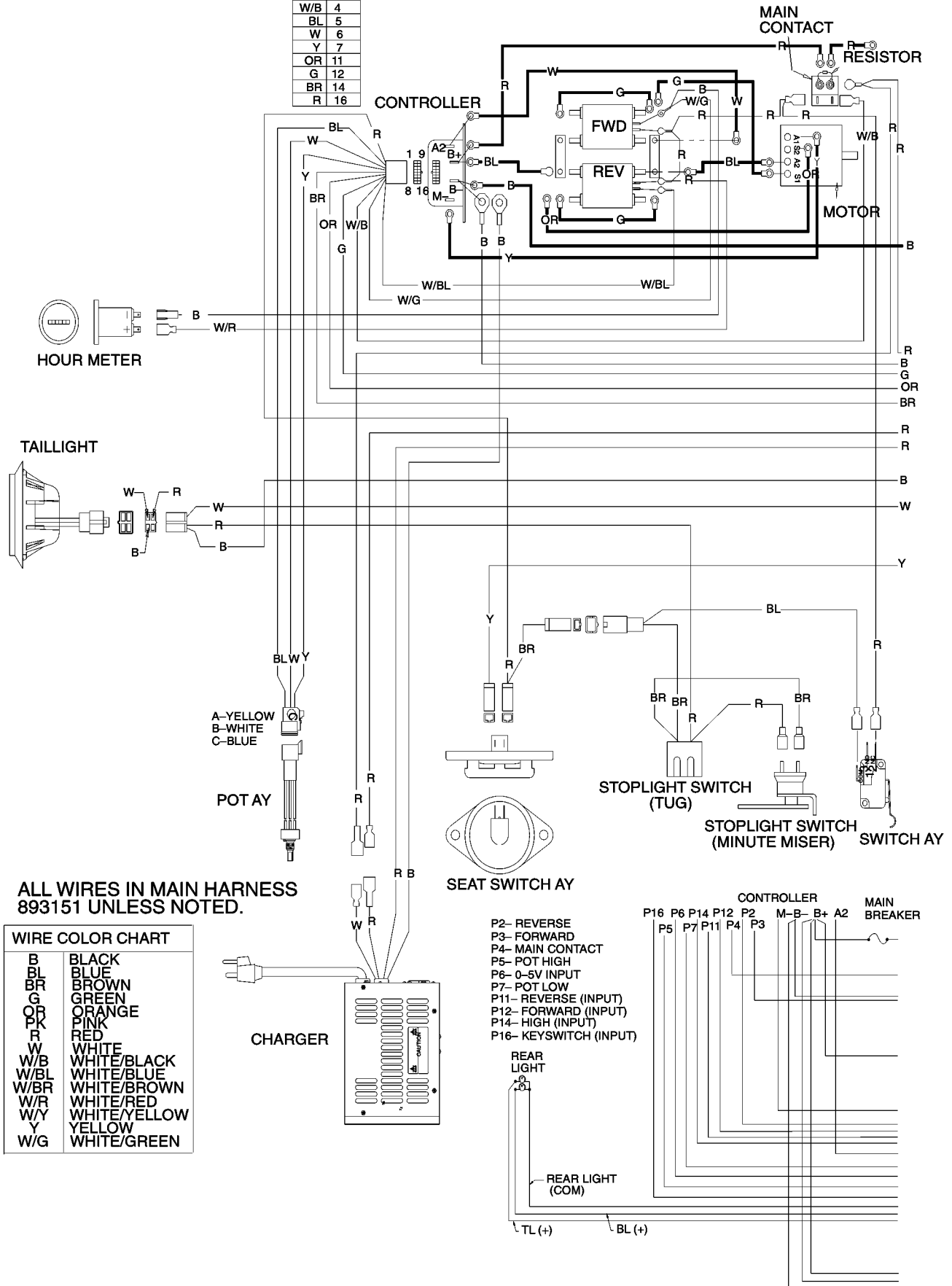

ALL WIRES IN MAIN HARNESS 893151 UNLESS NOTED.

WIRE COLOR CHART	
B	BLACK
BL	BLUE
BR	BROWN
G	GREEN
OR	ORANGE
PK	PINK
R	RED
W	WHITE
W/B	WHITE/BLACK
W/BL	WHITE/BLUE
W/BR	WHITE/BROWN
W/R	WHITE/RED
W/Y	WHITE/YELLOW
Y	YELLOW
W/G	WHITE/GREEN

- P2- REVERSE
- P3- FORWARD
- P4- MAIN CONTACT
- P5- POT HIGH
- P6- 0-5V INPUT
- P7- POT LOW
- P11- REVERSE (INPUT)
- P12- FORWARD (INPUT)
- P14- HIGH (INPUT)
- P16- KEYSWITCH (INPUT)

REAR LIGHT

REAR LIGHT (COM)

TL (+)

BL (+)

# WIRING DIAGRAM

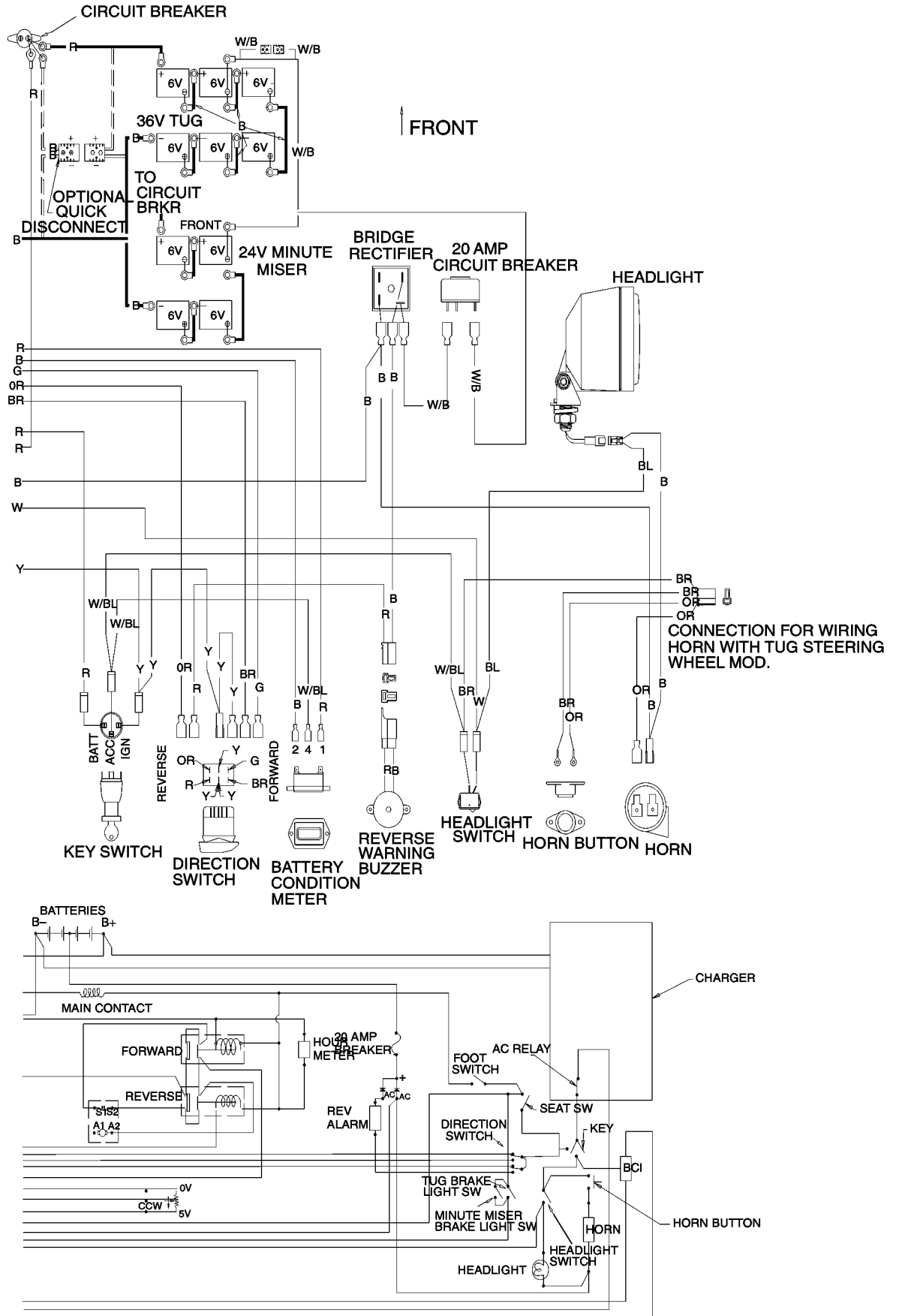

# WIRING DIAGRAM FOR VEHICLES WITH SERIAL NO. 9601-2229 OR LATER

W/BL	2
W/G	3
W/B	4
BL	5
W	6
Y	7
OR	11
G	12
BR	14
R	16

