



ELECTRIC OWNER'S MANUAL
RXV FLEET
FREEDOM®
SHUTTLE™ 2+2

610992

ISSUED FEBRUARY 2009

REVISED JUNE 2012



A Textron Company

SAFETY

For any questions on material contained in this manual, contact an authorized representative for clarification.

Read and understand all labels located on the vehicle. Always replace any damaged or missing labels.

On steep hills it is possible for vehicles to coast at greater than normal speeds encountered on a flat surface. To prevent loss of vehicle control and possible serious injury, speeds should be limited to no more than the maximum speed on level ground. See GENERAL SPECIFICATIONS. Limit speed by applying the service brake.

Catastrophic damage to the drivetrain components due to excessive speed may result from driving the vehicle above specified speed. Damage caused by excessive speed may cause a loss of vehicle control, is costly, is considered abuse and will not be covered under warranty.

Use extra caution when towing the vehicle(s). Do not tow a single vehicle at speeds in excess of 12 mph (19 kph). Do not tow more than three vehicles at a time. Do not exceed 5 mph (8 kph) while towing multiple vehicles. Towing the vehicle at above the recommended speed may result in personal injury and/or damage to the vehicle and other property. Vehicles equipped with the AC Drive motor must be towed with the Run-Tow switch, located under the passenger seat, in the 'Tow' position.

If the vehicle is to be used in a commercial environment, signs similar to the ones illustrated should be used to warn of situations that could result in an unsafe condition

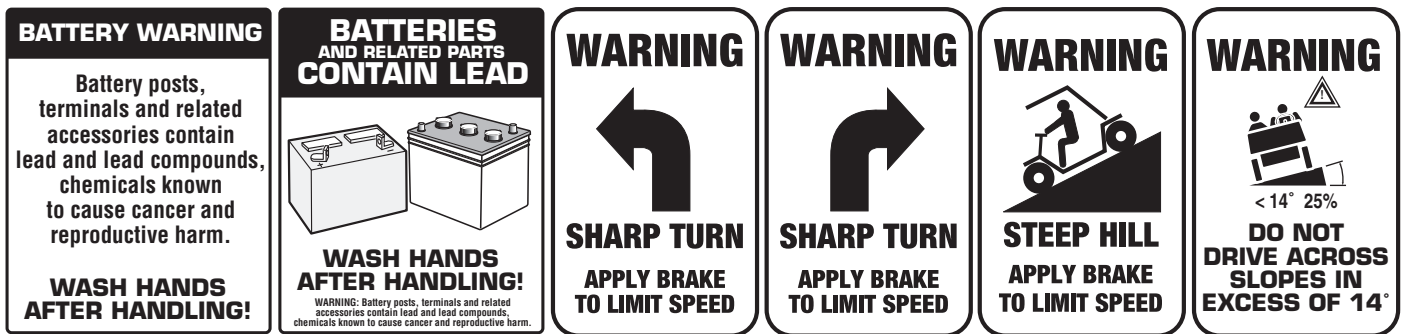

Observe these **NOTICES, CAUTIONS, WARNINGS** and **DANGERS**; be aware that servicing a vehicle requires mechanical skill and a regard for conditions that could be hazardous. Improper service or repair may damage the vehicle or render it unsafe.

NOTES, CAUTIONS, WARNINGS AND DANGERS

NOTICE

Address practices not related to personal injury.

CAUTION

Indicates a hazardous situation which, if not avoided, could result in minor or moderate injury.

WARNING

Indicates a hazardous situation which, if not avoided, could result in death or serious injury.

DANGER

Indicates a hazardous situation which, if not avoided, will result in death or serious injury.

Please observe these **NOTES, CAUTIONS** and **WARNINGS**; be aware that servicing a vehicle requires mechanical skill and a regard for conditions that could be hazardous. Improper service or repair may damage the vehicle or render it unsafe.

WARNING

Battery posts, terminals and related accessories contain lead and lead compounds. Wash hands after handling.

(NOTES, CAUTIONS, WARNINGS AND DANGERS CONTINUED ON INSIDE OF BACK COVER)

OWNER'S GUIDE

ELECTRIC POWERED FLEET & PERSONAL GOLF CARS

RXV GOLF CAR

RXV FREEDOM™

RXV SHUTTLE 2 + 2

STARTING MID-MODEL YEAR 2009

(MANUFACTURED BEGINNING FEBRUARY 23, 2009)

E-Z-GO Division of TEXTRON Inc. reserves the right to incorporate engineering and design changes to products in this Manual, without obligation to include these changes on units leased/sold previously.

The information contained in this Manual may be revised periodically by the E-Z-GO Division, and therefore is subject to change without notice.

The E-Z-GO Division **DISCLAIMS LIABILITY FOR ERRORS IN THIS MANUAL**, and the E-Z-GO Division **SPECIFICALLY DISCLAIMS LIABILITY FOR INCIDENTAL AND CONSEQUENTIAL DAMAGES** resulting from the use of the information and materials in this Manual.

These are the original instructions as defined by 2006/42/EC.

TO CONTACT US

NORTH AMERICA:

TECHNICAL ASSISTANCE & WARRANTY PHONE: 1-800-774-3946, FAX: 1-800-448-8124

SERVICE PARTS PHONE: 1-888-GET-EZGO (1-888-438-3946), FAX: 1-800-752-6175

INTERNATIONAL:

SALES PHONE: 001-706-798-4311, FAX: 001-706-771-4609

E-Z-GO DIVISION OF TEXTRON INC., 1451 MARVIN GRIFFIN ROAD, AUGUSTA, GEORGIA USA 30906-3852

GENERAL INFORMATION

This vehicle has been designed and manufactured in the United States of America (USA) as a 'World Vehicle'. The Standards and Specifications listed in the following text originate in the USA unless otherwise indicated.

The use of non Original Equipment Manufacturer (OEM) approved parts may void the warranty.

Overfilling batteries may void the warranty.

BATTERY PROLONGED STORAGE

All batteries will self discharge over time. The rate of self discharge varies depending on the ambient temperature and the age and condition of the batteries.

A fully charged battery will not freeze in winter temperatures unless the temperature falls below -75° F (-60° C).

For winter storage, the batteries must be clean, fully charged and disconnected from any source of electrical drain.

On all electric vehicles, set the key switch to 'OFF'. Make sure that the 'RUN/TOW' switch, located under the passenger seat, is set to the 'RUN/STORAGE' position; if the switch is left in the 'TOW' position, it will drain the batteries.

As with all electric vehicles, the batteries must be checked and recharged as required or at a minimum of 30 day intervals.

TABLE OF CONTENTS

SECTION TITLE	PAGE NO.
SAFETY	Inside Covers
GENERAL INFORMATION	ii
SAFETY INFORMATION	v
LABELS AND PICTOGRAMS	ix
SERIAL NUMBER LOCATION	1
BEFORE INITIAL USE.....	1
PORTABLE CHARGER.....	2
PORTABLE CHARGER INSTALLATION	2
USING THE CHARGER.....	3
UNDERSTANDING THE CHARGER	3
LED OPERATION CODES.....	4
LED FAULT CODES	4
MAINTENANCE INSTRUCTIONS.....	4
CONTROLS AND INDICATORS.....	5
KEY SWITCH/DIRECTION SELECTOR	5
SPEEDOMETER/STATE OF CHARGE METER	5
HEADLIGHT SWITCH.....	6
TURN SIGNAL SWITCH	6
HORN	6
ACCELERATOR & BRAKE PEDALS	6
PARKING BRAKE.....	6
RUN/TOW SWITCH.....	6
OPERATING THE VEHICLE.....	7
REGENERATIVE BRAKING	7
PEDAL-UP BRAKING	8
HIGH PEDAL DISABLE FEATURE	8
STARTING AND DRIVING.....	8
STARTING VEHICLE ON A HILL.....	8
COASTING	8
LABELS AND PICTOGRAMS	8
SUN TOP AND WINDSHIELD	8
VEHICLE CLEANING & CARE.....	8
VEHICLE CLEANING.....	8
REPAIR.....	9
LIFTING THE VEHICLE	9
WHEELS AND TIRES	10
TIRE REPAIR.....	10
WHEEL INSTALLATION	11
LIGHT BULB REPLACEMENT	11
HEAD LIGHT BULB REPLACEMENT	11
TURN SIGNAL BULB REPLACEMENT	12
TAILLIGHT/BRAKE LIGHT BULB REPLACEMENT	12

TABLE OF CONTENTS

SECTION TITLE	PAGE NO.
TRANSPORTING THE VEHICLE	12
TOWING	12
HAULING	13
SERVICE AND MAINTENANCE	13
ROUTINE MAINTENANCE	14
TIRE INSPECTION	14
REAR AXLE	14
HARDWARE	14
CAPACITIES AND REPLACEMENT PARTS	15
PERIODIC SERVICE SCHEDULE	16
BATTERIES AND CHARGING	17
SAFETY	17
BATTERY	17
BATTERY MAINTENANCE	18
AT EACH CHARGING CYCLE	18
MONTHLY	18
ELECTROLYTE LEVEL AND WATER	19
CLEANING BATTERIES	
BATTERY REMOVAL & INSTALLATION	20
PROLONGED STORAGE	22
BATTERY CHARGING	23
TROUBLESHOOTING	23
HYDROMETER	23
USING A HYDROMETER	24
GENERAL SPECIFICATIONS	27
RXV ELECTRIC - FLEET VEHICLE SPECIFICATIONS	28
RXV ELECTRIC - FREEDOM VEHICLE SPECIFICATIONS	29
RXV ELECTRIC - SHUTTLE 2 + 2 VEHICLE SPECIFICATIONS	30
DECLARATION OF CONFORMITY (EUROPE ONLY)	35

SAFETY INFORMATION

Read all of manual to become familiar with vehicle. Pay attention to all NOTICES, CAUTIONS, WARNINGS and DANGERS.

This manual has been designed to assist in maintaining the vehicle in accordance with procedures developed by the manufacturer. Adherence to these procedures and troubleshooting tips will ensure the best possible service from the product. To reduce the chance of personal injury or property damage, the following must be carefully observed:



CAUTION

Certain replacement parts can be used independently and/or in combination with other accessories to modify an E-Z-GO-manufactured vehicle to permit the vehicle to operate at or in excess of 20 mph. When an E-Z-GO-manufactured vehicle is modified in any way by the Distributor, Dealer or customer to operate at or in excess of 20mph, UNDER FEDERAL LAW the modified product will be a Low Speed Vehicle (LSV) subject to the strictures and requirements of Federal Motor Vehicle Safety Standard 571.500. In these instances, pursuant to Federal law the Distributor or Dealer MUST equip the product with headlights, rear lights, turn signals, seat belts, top, horn and all other modifications for LSV's mandated in FMVSS 571.500, and affix a Vehicle Identification Number to the product in accordance with the requirements of FMVSS 571.565. Pursuant to FMVSS 571.500, and in accordance with the State laws applicable in the places of sale and use of the product, the Distributor, Dealer or customer modifying the vehicle also will be the Final Vehicle Manufacturer for the LSV, and required to title or register the vehicle as mandated by State law.

E-Z-GO will NOT approve Distributor, Dealer or customer modifications converting E-Z-GO products into LSV's.

The Company recommends that all E-Z-GO products sold as personal transportation vehicles BE OPERATED ONLY BY PERSONS WITH VALID DRIVERS LICENSES, AND IN ACCORDANCE WITH APPLICABLE STATE REQUIREMENTS. This restriction is important to the SAFE USE AND OPERATION of the product.

All customers should adhere to this SAFETY RESTRICTION, in connection with the use of all E-Z-GO products, new and used, the Distributor or Dealer has reason to believe may be operated in personal transportation applications.

Information on FMVSS 571.500 can be obtained at Title 49 of the Code of Federal Regulations, section 571.500, or through the Internet at the website for the U.S. Department of Transportation - at Dockets and Regulation, then to Title 49 of the Code of Federal Regulations (Transportation)

GENERAL

All vehicles can be used for a variety of tasks beyond the original intended use of the vehicle; therefore, it is impossible to anticipate and warn against every possible combination of circumstances that may occur. No warning can take replace good common sense and prudent driving practices.

Good common sense and prudent driving practices do more to prevent accidents and injury than all of the warnings and instructions combined. E-Z-GO strongly suggests that all users and maintenance personnel read this entire manual paying particular attention to the CAUTIONS, WARNINGS and DANGERS contained therein.

If you have any questions regarding this vehicle, contact your E-Z-GO dealer or write to the address on the back cover of this publication, Attention: Customer Care Department.

E-Z-GO reserves the right to make design changes without obligation to make these changes on units previously sold. The information contained in this manual is subject to change without notice.

E-Z-GO IS NOT LIABLE FOR ERRORS IN THIS MANUAL. E-Z-GO IS NOT LIABLE FOR INCIDENTAL OR CONSEQUENTIAL DAMAGES THAT RESULT FROM THE USE OF THE MATERIAL IN THIS MANUAL.

This vehicle conforms to the current applicable standard(s) for safety and performance requirements.

These vehicles are designed and manufactured for off-road use. They DO NOT conform to Federal Motor Vehicle Safety Standards of the United States of America (USA) and are not equipped for operation on public streets. Some communities may permit these vehicles to be operated on their streets on a limited basis and in accordance with local ordinances.

With electric powered vehicles, be sure that all electrical accessories are grounded directly to the battery (-) post.

Never use the chassis or body as a ground connection.

Refer to GENERAL SPECIFICATIONS for vehicle seating capacity.

SAFETY INFORMATION

Read all of manual to become familiar with vehicle. Pay attention to all NOTICES, CAUTIONS, WARNINGS and DANGERS.

Never modify the vehicle in any way that will alter the weight distribution of the vehicle, decrease its stability or increase the speed or extend the stopping distance beyond the factory specification. Such modifications can result in serious personal injury or death.

Do not make any such modifications or changes. E-Z-GO prohibits and disclaims responsibility for all such modifications or and alterations which would adversely affect the safety of the vehicle.

Vehicles that are capable of higher speeds must limit their speed to no more than the speed of other vehicles when used in a golf course environment. Additionally, speed should be further moderated by the environmental conditions, terrain and common sense.

Operation of the vehicle is limited to persons above the height of 59 inches (150 cm).

GENERAL OPERATION

ALWAYS:

- use the vehicle in a responsible manner and maintain the vehicle in safe operating condition
- read and observe all warnings and operation instruction labels affixed to the vehicle
- follow all safety rules established in the area where the vehicle is being operated
- leave the vehicle when there is a risk of lightning
- reduce speed to compensate for poor terrain or conditions
- apply service brake to control speed on steep grades
- maintain adequate distance between vehicles
- maintain adequate distance between vehicles
- reduce speed in wet areas
- use extreme caution when approaching sharp or blind turns
- use extreme caution when driving over loose terrain
- use extreme caution in areas where pedestrians are present

MAINTENANCE

ALWAYS:

- replace damaged or missing warning, caution or information labels
- maintain the vehicle in accordance with the manufacturer's periodic service schedule
- ensure that repairs are performed by trained and qualified personnel
- follow the manufacturer's maintenance procedures
- insulate any tools used within the battery area in order to prevent sparks or battery explosion
- check the polarity of each battery terminal and be sure to rewire the batteries correctly
- use specified replacement parts, NEVER use replacement parts of lesser quality
- use recommended tools
- determine that tools and procedures not specifically recommended by the manufacturer will not compromise the safety of personnel nor jeopardize the safe operation of the vehicle
- support the vehicle using wheel chocks and jack stands, NEVER get under a vehicle that is supported by a jack, lift the vehicle in accordance with the manufacturer's instructions
- maintain the vehicle in an area away from exposed flame or persons who are smoking
- be aware that a vehicle that is not performing as designed is a potential hazard and must not be operated
- test drive the vehicle after any repairs or maintenance in a safe area that is free of both vehicular and pedestrian traffic
- keep complete records of the maintenance history of the vehicle

SAFETY INFORMATION

Read all of manual to become familiar with vehicle. Pay attention to all NOTICES, CAUTIONS, WARNINGS and DANGERS.

The manufacturer cannot anticipate all situations, therefore people attempting to maintain or repair the vehicle must have the skill and experience to recognize and protect themselves from potential situations that could result in severe personal injury or death and damage to the vehicle. Use extreme caution and, if unsure as to the potential for injury, refer the repair or maintenance to a qualified mechanic.

VENTILATION

Hydrogen gas is generated in the charging cycle of batteries and is explosive in concentrations as low as 4%. Because hydrogen gas is lighter than air, it will collect in the ceiling of buildings necessitating proper ventilation. Five air exchanges per hour is considered the minimum requirement.

NEVER charge a vehicle in an area that is subject to flame or spark. Pay particular attention to natural gas or propane water heaters and furnaces.

Always use a dedicated circuit for each battery charger. Do not permit other appliances to be plugged into the receptacle when the charger is in operation.

Chargers must be installed and operated in accordance with charger manufacturers recommendations or applicable electrical code (whichever is higher).

Read all of manual to become familiar with this vehicle. Pay attention to all NOTICES, CAUTIONS, WARNINGS and DANGERS.

LABELS & PICTOGRAMS

LABELS & PICTOGRAMS

Read all of manual to become familiar with this vehicle. Pay attention to all NOTICES, CAUTIONS, WARNINGS and DANGERS.

⚠ WARNING Failure to follow these instructions can result in **SERIOUS INJURY** or **DEATH**

608528

Except where PERMITTED BY LAW: NEVER drive on public roads. • Drivers must possess a valid drivers license in accordance with local state law.

AVOID FALLS from the vehicle: Do not start moving until all occupants are **PROPERLY SEATED** and **HOLDING ON**. • **KEEP** entire body **INSIDE VEHICLE** while moving.

Reduce the RISK OF ACCIDENTS: Always **DRIVE SLOWLY** in congested areas, on wet or loose terrain, and when backing up. • **DRIVE SLOWLY** when turning and **AVOID** sudden stops. **ALWAYS** drive straight up and down slopes. Do not coast, use **BRAKE** when going down a slope. • **NEVER** drive this vehicle under the influence of drugs or alcohol.

This vehicle is NOT A TOY: Drive responsibly. • **NEVER** leave children unattended or allow children to play on the vehicle. • **NEVER** leave the key in the vehicle when parked.

DO NOT OVERLOAD this vehicle: **NEVER** carry more than 2 occupants on each bench seat. • Do not exceed vehicle **WEIGHT CAPACITY** (see Owner's Manual).

DO NOT MODIFY this vehicle: **NEVER** alter this vehicle to increase travel speeds above factory specifications. • **ONLY** authorized E-Z-GO dealers should alter the vehicle using approved parts. • Alterations not approved or tested by E-Z-GO can create unsafe conditions and increase your chance of having an accident.

608528

⚠ WARNING Failure to follow these instructions can result in **SERIOUS INJURY** or **DEATH**

608522

Except where PERMITTED BY LAW: To be operated by persons with valid drivers license, in accordance with state requirements. Operate from Driver's side only. For non-road use, and in designated areas only. Do not operate under the influence of drugs or alcohol.

AVOID FALLS from the vehicle: All occupants must be fully seated, keep entire body inside vehicle and hold on while vehicle is in motion.

STARTING the vehicle: Apply service brake, move direction selector to desired position and accelerate smoothly. On Gas Vehicle, direction selector is the F-N-R. On Electric vehicle, direction selector is the key switch.

DO NOT OVERLOAD this vehicle: Maximum vehicle payload is 800 lbs. (363 kg) including a maximum of 2 persons, options, and accessories.

Drive with CAUTION: Drive slowly straight up and down slopes and in turns. Use care in reverse, congested areas, and wet or loose terrain.

STOPPING the vehicle: To stop, release accelerator pedal and apply service brake.

PARKING the vehicle: Before leaving vehicle, turn key 'OFF'. On Gas vehicle, move the direction selector to "FORWARD" and engage park brake.

608522

608522 FLEET VEHICLES

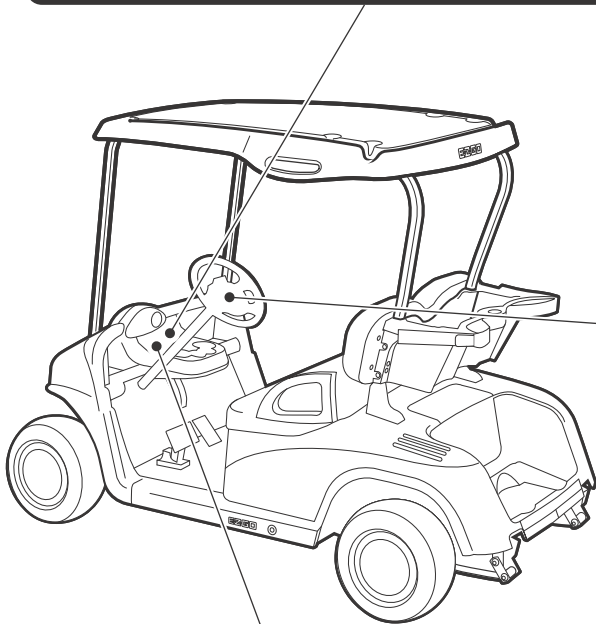

⚠ WARNING

OPERATING INSTRUCTIONS

608529

BEFORE OPERATING

- READ all warning labels and the owner's manual. Contact an authorized E-Z-GO dealer or visit www.ezgo.com for a replacement manual.
- This vehicle is equipped for personal use in most communities. However, state law or local rules may require additional equipment in your community.

SAFE OPERATION

- Turn key to "ON" - select "forward" or "reverse" - release the parking brake (Gas vehicle only) - then slowly depress accelerator pedal.
- Always bring the vehicle to a complete stop **BEFORE** shifting the direction selector.
- Operate from the driver's seat **ONLY**.

PARKING

- **ALWAYS** fully engage the parking brake and remove the key **BEFORE** leaving the vehicle. In an electric vehicle set the direction selector to "neutral" and in a gasoline vehicle set the selector to "forward".

MAINTENANCE

- This vehicle requires regularly scheduled maintenance (see owner's manual). **ONLY** qualified personnel should service this vehicle.

608529

1. To Prevent Roll-Back On a Hill From a Stopped Position

2. Apply Service Brake With Left Foot

3. Fully Release Park Brake

4. Depress Accelerator While Releasing Service Brake As Vehicle Starts

74443G01

74443G01

Read all of manual to become familiar with this vehicle. Pay attention to all NOTICES, CAUTIONS, WARNINGS and DANGERS.

WARNING

- This device is ONLY to be used for towing E-Z-GO vehicles. NEVER tow other vehicles or equipment. READ Owner's Manual before towing. NO RIDERS in towed cars.
- FULLY ENGAGE coupling. Rubber latch-stop must be under latch release lever.
- NEVER tow more than 3 vehicles at one time. Max speed towing 2 or 3 vehicles is 5 mph. Max speed towing 1 vehicle is 12 mph.
- DRIVE SLOWLY. It is not recommended to tow vehicle over rough or unsafe terrain or on grades greater than 10%.
- MONTHLY INSPECTION: tow bar pins, attaching hardware, and front frame attachment of towed cars. Replace worn or damaged parts. CHECK alignment of wheels on towed cars.





611716

WARNING

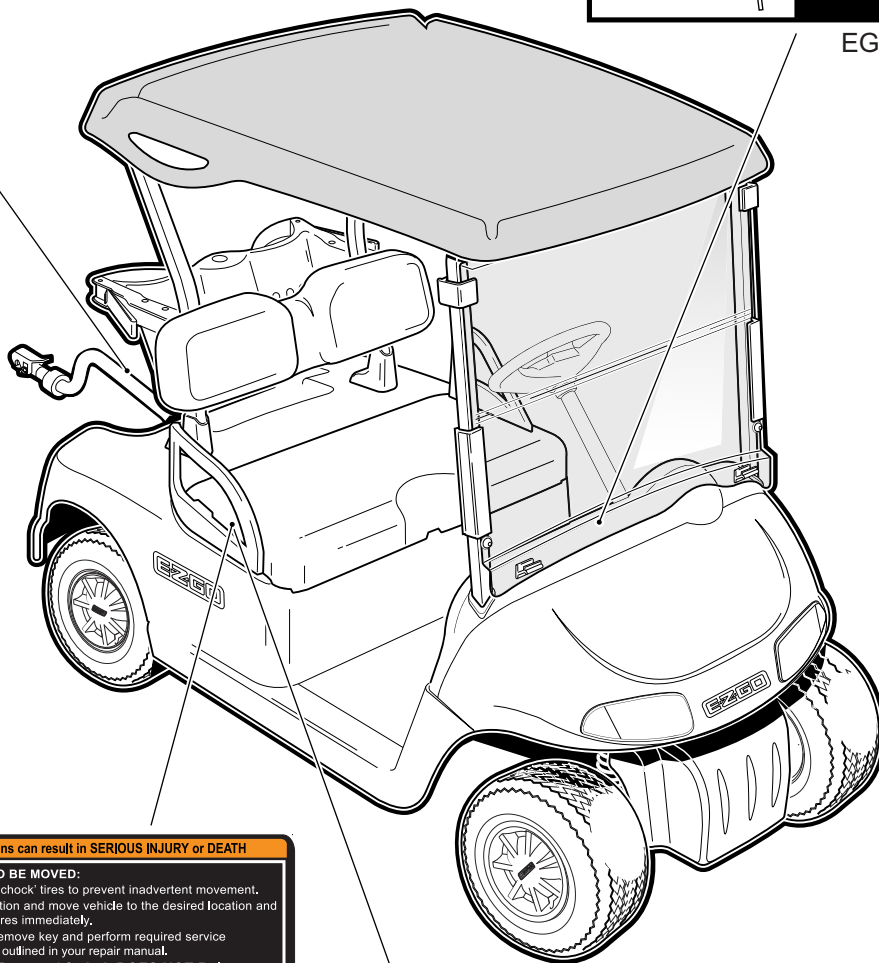

Windshields do not provide protection from golf balls or other flying objects.

EGWHL14



WARNING Failure to follow these instructions can result in SERIOUS INJURY or DEATH

IF VEHICLE IS INOPERABLE AND NEEDS TO BE MOVED:

- Turn the ignition key to the 'N' position and 'chock' tires to prevent inadvertent movement.
- Flip the RUN-TOW switch to the 'TOW' position and move vehicle to the desired location and park it properly on level ground and chock tires immediately.
- Turn the ignition key to the 'OFF' position, remove key and perform required service procedures following all Safety Guidelines as outlined in your repair manual.

In Case of Total Power Loss and the 'Run-tow' Switch DOES NOT Release the Brake to Move the Vehicle :

- Remove this plastic cover by removing 3 plastic fasteners. See illustrations below.
- See emergency brake release instruction under this panel.

Push center of fastener with vehicle key. When center is depressed lift fastener to remove.



To reuse fastener push center stem up then install fastener through shield into hole.



To secure fastener in place press down on center stem until flush with head of fastener.



609987

WARNING Failure to follow these instructions can result in SERIOUS INJURY or DEATH

THIS PROCEDURE SHOULD ONLY BE TO CLEAR VEHICLE FROM AN UNSAFE AREA AND BE PERFORMED ONLY BY QUALIFIED TRAINED PERSONNEL.

In Case Of Total Power Loss And The 'Run-tow' Switch DOES NOT Release The Brake To Move The Vehicle:

- Turn the ignition key to the 'OFF' position and 'chock' tires to prevent inadvertent movement.
- Identify the 'Auxiliary Power' line (3) and remove the Weather Pack Seal (4) from the connector.
- Identify the 'Primary Power' line (1) connector and disconnect the line (2).
- Connect 'Auxiliary Power' line (3) to 'Primary Power' line (1) which will release the brake. THIS WILL CAUSE THE VEHICLE TO MOVE IMMEDIATELY IF NOT ON LEVEL GROUND.
- Move vehicle to desired location, and park it properly on level ground, chock tires. IMMEDIATELY DISCONNECT AUXILIARY POWER AND RECONNECT 'PRIMARY POWER' (1, 2) FOR SAFETY AND TO AVOID BATTERY DRAIN.
- Reconnect the Weather Pack Seal (4) to the Auxiliary Power line (3) and perform required service procedures following all Safety guidelines as outlined in your repair manual.

609694

WARNING

- DO NOT alter or tamper with this unit. Unauthorized modifications can result in SERIOUS INJURY or damage to the vehicle and will void the warranty.
- To disable electrical system, turn key switch to 'OFF' and remove battery wires.
- ALWAYS turn key to 'OFF' before disconnecting or reconnecting battery wires. ELECTRICAL ARC or BATTERY EXPLOSION can occur if key is not in the 'OFF' position.
- WAIT 30 seconds after reconnecting batteries BEFORE turning key switch to 'REVERSE', 'FORWARD' or 'NEUTRAL' positions.

TOWING - Always select 'TOW' position before towing.

TOW RUN STORAGE



612594

612594

LABELS & PICTOGRAMS

Read all of manual to become familiar with this vehicle. Pay attention to all NOTICES, CAUTIONS, WARNINGS and DANGERS.

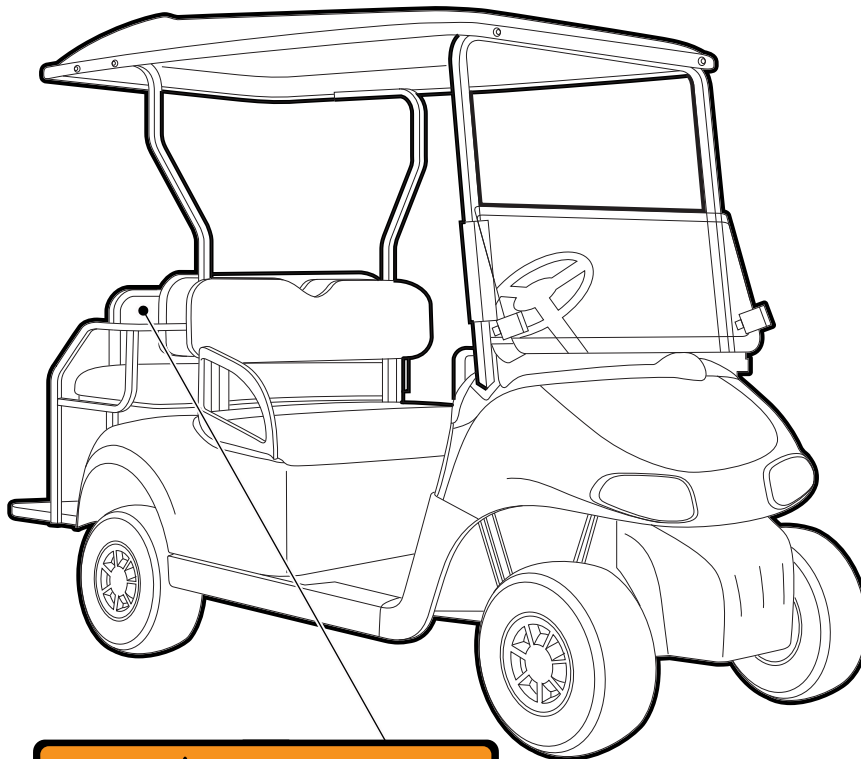

⚠ WARNING
**FAILURE TO FOLLOW THESE INSTRUCTIONS
MAY RESULT IN SEVERE PERSONAL INJURY.**

AVOID FALLS from the vehicle and other SERIOUS INJURIES:

- Never attempt to enter or exit a moving vehicle.
- AVOID standing in front of, or behind vehicle.
- ONLY 2 occupants per seat.
- Always remain PROPERLY SEATED and HOLDING ON.
- KEEP feet, legs, hands, and arms inside the vehicle at all times.
- NEVER leave children unattended. Children may need assistance to remain properly seated and holding on.

608537

608537

LABELS & PICTOGRAMS

Read all of manual to become familiar with this vehicle. Pay attention to all NOTICES, CAUTIONS, WARNINGS and DANGERS.

READ THE MANUAL
OPERATE ACCORDING TO LOCAL LAWS AND REGULATIONS
USE CAUTION IN BAD WEATHER

GASOLINE VEHICLES	FORWARD OPERATION	REVERSE OPERATION	PARK VEHICLE
	* TURN KEY TO 'ON' * MOVE DIRECTION SELECTOR TO 'F' * PRESS ACCELERATOR PEDAL GENTLY	* TURN KEY TO 'ON' * MOVE DIRECTION SELECTOR TO 'R' * PRESS ACCELERATOR PEDAL GENTLY	* MOVE DIRECTION SELECTOR TO 'F' * TURN KEY TO 'OFF' * APPLY PARKING BRAKE

OPERATE FROM DRIVER SIDE ONLY
DO NOT STAND UP AND KEEP ENTIRE BODY INSIDE VEHICLE
MINIMUM HEIGHT TO OPERATE VEHICLE IS 150 CM

MAXIMUM RAMP OR HILL
MAXIMUM CROSS RAMP OR HILL

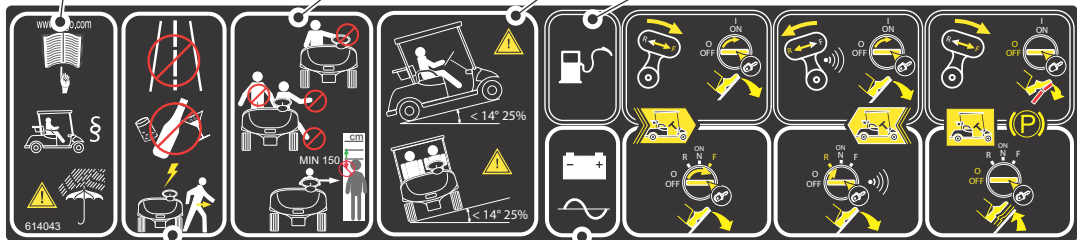

614043 CE VEHICLES

DO NOT DRIVE ON HIGHWAY
DO NOT OPERATE IF USING DRUGS OR ALCOHOL
DO NOT OPERATE VEHICLE WHEN LIGHTNING IS IN THE AREA

ELECTRIC VEHICLES	FORWARD OPERATION	REVERSE OPERATION	PARK VEHICLE
	* TURN KEY TO 'F' * PRESS ACCELERATOR PEDAL GENTLY	* TURN KEY TO 'R' * GENTLY PRESS ACCELERATOR PEDAL	* TURN KEY TO 'OFF'

READ THE MANUAL REPLACEMENT AVAILABLE AT www.ezgo.com

WARNING: NEGATIVE GROUND ELECTRICAL SYSTEM



608818

WARNING: SHORTING ACROSS TERMINALS MAY CAUSE BATTERY EXPLOSION

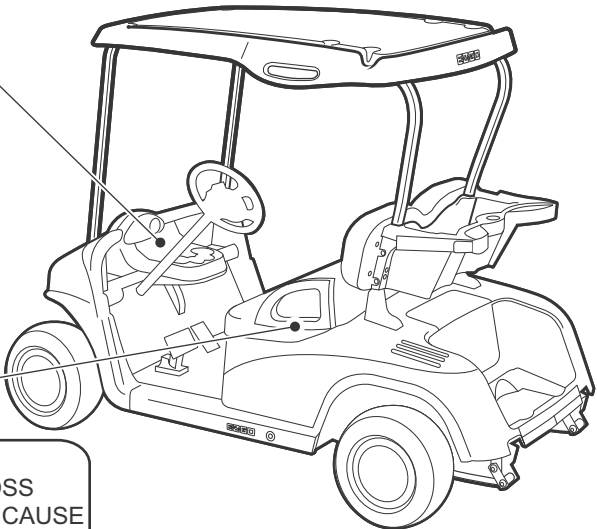

LABELS & PICTOGRAMS

Read all of manual to become familiar with this vehicle. Pay attention to all **NOTICES, CAUTIONS, WARNINGS and DANGERS.**

GASOLINE VEHICLES	FORWARD OPERATION * TURN KEY TO 'ON' * MOVE DIRECTION SELECTOR TO 'F' * PRESS ACCELERATOR PEDAL GENTLY	REVERSE OPERATION * TURN KEY TO 'ON' * MOVE DIRECTION SELECTOR TO 'R' * PRESS ACCELERATOR PEDAL GENTLY	PARK VEHICLE * MOVE DIRECTION SELECTOR TO 'F' * TURN KEY TO 'OFF' * APPLY PARKING BRAKE
--------------------------	--	--	---

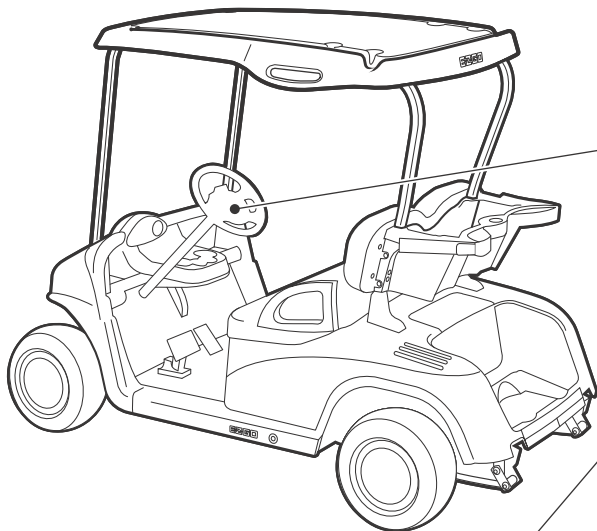

WARNING	READ THE MANUAL REPLACEMENT IS AVAILABLE AT www.ezgo.com	READ ALL LABELS	OPERATE FROM DRIVER SIDE ONLY	OPERATE ACCORDING TO LOCAL LAWS AND REGULATIONS	MAINTAIN ACCORDING TO SERVICE & REPAIR MANUAL AVAILABLE AT www.ezgo.com
----------------	--	-----------------	-------------------------------	---	---

MINIMUM HEIGHT TO OPERATE VEHICLE IS 150 CM	DO NOT OPERATE VEHICLE WHEN LIGHTNING IS IN THE AREA
---	--

ELECTRIC VEHICLES	FORWARD OPERATION * TURN KEY TO 'F' * PRESS ACCELERATOR PEDAL GENTLY	REVERSE OPERATION * TURN KEY TO 'R' * PRESS ACCELERATOR PEDAL GENTLY	PARK VEHICLE * TURN KEY TO 'OFF'
--------------------------	---	---	--

LABELS & PICTOGRAMS

Read all of manual to become familiar with this vehicle. Pay attention to all NOTICES, CAUTIONS, WARNINGS and DANGERS.

DO NOT TOW MORE THAN 3 VEHICLES MAX 12 mph (19 kph) TOWING 1 VEHICLE
 DO NOT DRIVE IN REVERSE WHEN TOWING VEHICLES MAX 5 mph (8 kph) TOWING 2 or 3 VEHICLES
 NO PASSENGERS IN TOWED VEHICLES
 DO NOT TOW VEHICLES OVER UNEVEN TERRAIN 10% MAX SLOPE FOR TOWING VEHICLES

TOW BAR OPERATION

- * PULL LOCKING COLLAR AWAY FROM LATCH AND PRESS ON LATCH TAB TO OPEN
- * PLACE LATCH OVER FRONT TOWING BRACKET
- * CLOSE LATCH AND MOVE LOCKING COLLAR UNDER LATCH TAB
- * DO NOT TOW MORE THAN 3 VEHICLES
- * 12 mph (19 kph) MAX SPEED TOWING 1 VEHICLE
- * DO NOT DRIVE IN REVERSE WHEN TOWING VEHICLES
- * NO PASSENGERS IN TOWED VEHICLES
- * DO NOT TOW VEHICLES OVER UNEVEN TERRAIN 10% MAXIMUM SLOPE FOR TOWING VEHICLES



READ THE MANUAL REPLACEMENT AVAILABLE AT www.ezgo.com

WARNING ENGAGE LOCKING COLLAR

WARNING DO NOT DRIVE FAST

WARNING INSPECT TOW BAR SYSTEM EVERY 30 DAYS

WARNING: ATTACH TOW BAR BEFORE TURNING KEY SWITCH TO 'TOW'

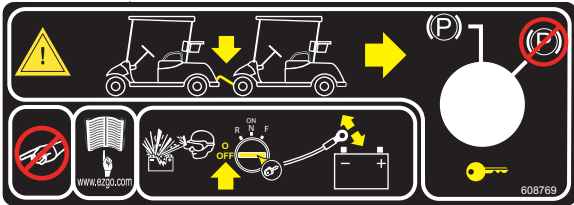

KEEP HANDS OUT

READ THE MANUAL REPLACEMENT AVAILABLE AT www.ezgo.com

TO REDUCE POSSIBILITY OF BATTERY EXPLOSION TURN KEY TO 'OFF' BEFORE DISCONNECTING OR CONNECTING BATTERY WIRES

WARNING READ THE MANUAL

CHECK THE WHEELS

UNPLUG 1 FROM 2 AND 3 FROM 4

PLUG 1 INTO 3

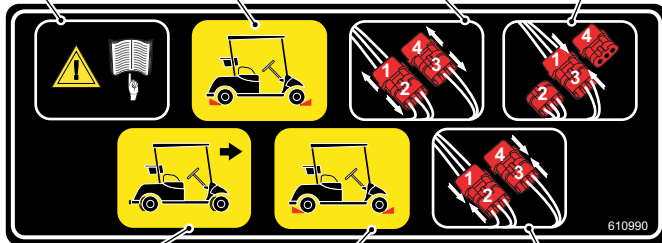

MOVE THE VEHICLE

CHECK THE WHEELS

PLUG 1 INTO 2 AND 3 INTO 4

610990

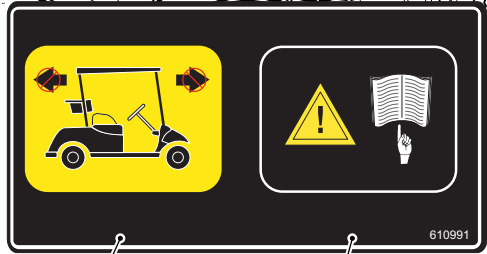

IF THE VEHICLE WILL NOT MOVE

WARNING READ THE MANUAL

LABELS & PICTOGRAMS

Read all of manual to become familiar with this vehicle. Pay attention to all **NOTICES, CAUTIONS, WARNINGS and DANGERS.**

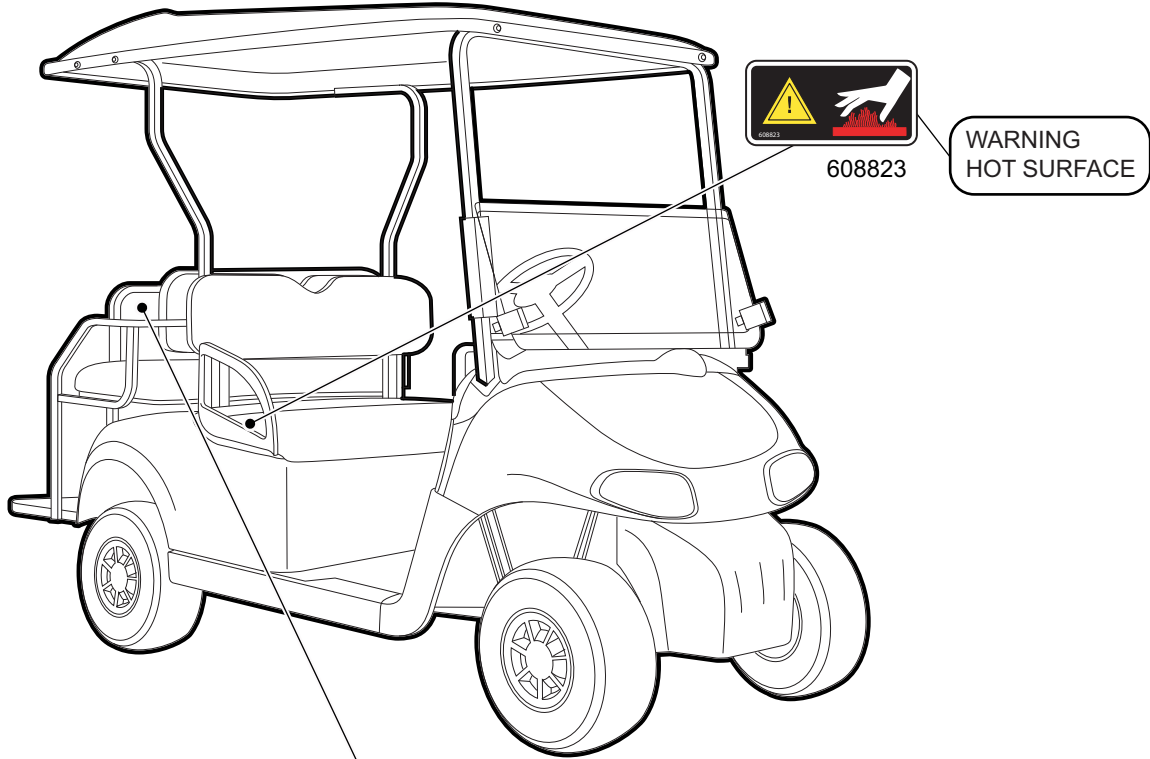

WARNING
HOT SURFACE

608823

READ THE MANUAL REPLACEMENT AVAILABLE AT www.ezgo.com	WARNING	OPERATE ACCORDING TO LOCAL LAWS AND REGULATIONS
--	----------------	---

NO MORE THAN 2 OCCUPANTS IN EACH SEAT	DO NOT STAND UP AND KEEP ENTIRE BODY INSIDE VEHICLE
---	--

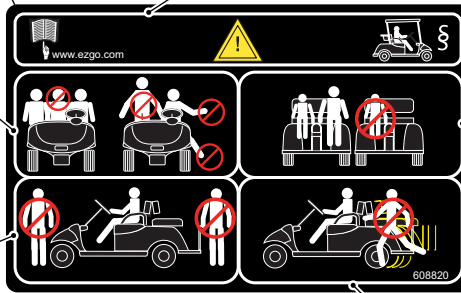

CHILDREN MUST BE
ACCOMPANIED BY
AN ADULT

DO NOT ALLOW
CHILDREN TO
RIDE ALONE

DO NOT STAND IN FRONT
OF OR BEHIND VEHICLE

608820

DO NOT GET ON OR OFF
A MOVING VEHICLE

OPERATION AND SERVICE INFORMATION

Read all of manual to become familiar with this vehicle. Pay attention to all NOTICES, CAUTIONS, WARNINGS and DANGERS.

Thank you for purchasing this vehicle. Before driving the vehicle, we ask you to spend some time reading this Owner's Guide. This guide contains the information that will assist you in maintaining this highly reliable vehicle. Some illustrations may show items that are optional for your vehicle. This guide covers the operation of several vehicles, therefore, some illustrations may not represent your vehicle. Physical differences in controls will be illustrated.

This vehicle has been designed and manufactured as a 'World Vehicle'. Some countries have individual requirements to comply with their specifications; therefore, some sections may not apply in your country.

Most of the service procedures in this guide can be accomplished using common automotive hand tools. Contact your service representative on servicing the vehicle in accordance with the Periodic Service Schedule.

Service Parts Manuals as well as Repair and Service Manuals are available from a local Distributor, an authorized Branch or the Service Parts Department. When ordering parts or requesting information for your vehicle, provide the vehicle model, serial number and manufacture date code.

SERIAL NUMBER LOCATION

Three serial number and manufacture date code labels are on the vehicle. One is placed on the steering column (Ref. Fig. 1), the second is located on the frame member under the front splash shield on the driver side (Ref. Fig. 2) and the third is located on the passenger side frame rail at the rear of the vehicle (Ref. Fig. 3).

In order to obtain correct components for the vehicle, the manufacture date code, serial number and vehicle model must be provided when ordering service parts.

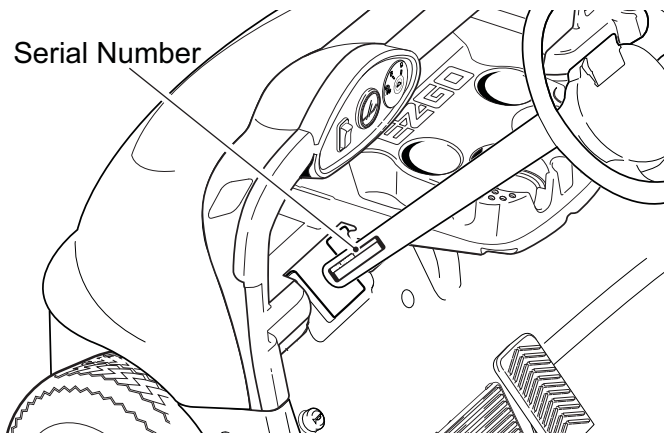

Fig. 1 Serial Number Location on Steering Column

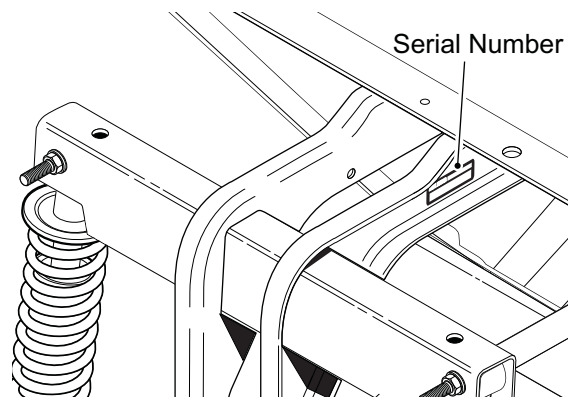

Fig. 2 Serial Number on Front Frame

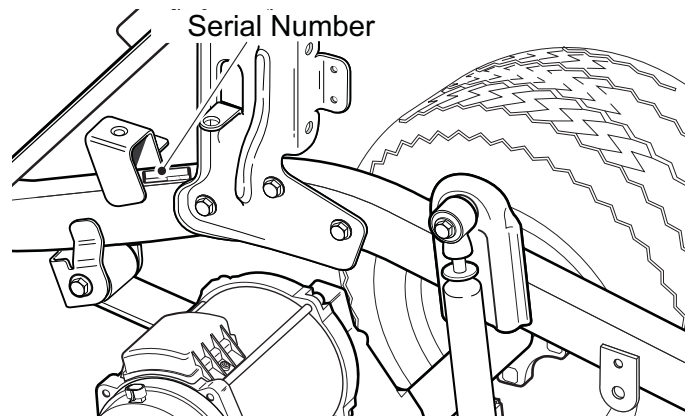

Fig. 3 Serial Number on Rear Frame

BEFORE INITIAL USE

Read and follow the safety label on the instrument panel. Be sure you understand how to operate the vehicle and its equipment as well as how to use it safely. Maintaining good performance depends to a large extent on the operator.

WARNING

Hydrogen gas is generated as a natural part of the lead acid battery charging process. A 4% concentration of hydrogen gas is explosive and could cause severe injury or death. Charging must take place in an area that is adequately ventilated (minimum of 5 air exchanges per hour).

To reduce the chance of battery explosion that could result in severe injury or death, never smoke around or charge batteries in an area that has open flame or electrical equipment that could cause an electrical arc.

OPERATION AND SERVICE INFORMATION

Read all of manual to become familiar with this vehicle. Pay attention to all NOTICES, CAUTIONS, WARNINGS and DANGERS.

Before a new vehicle is put into operation, the items shown in the **INITIAL SERVICE CHART** must be performed (Ref. Fig. 4).

The vehicle batteries must be fully charged before initial use.

Check for correct tire inflation. See GENERAL SPECIFICATIONS.

Determine and record the braking distance required to stop the vehicle for future brake performance tests.

Remove the protective clear plastic from the seat bottom and back rest before placing the vehicle in service

ITEM	SERVICE OPERATION
Batteries	Charge batteries
Seats	Remove protective plastic covering
Brakes	Check operation
	Establish acceptable stopping distance
Tires	Check air pressure (see SPECIFICATIONS)
Portable Charger	Remove from vehicle and properly mount

Fig. 4 Initial Service Chart

PORTABLE CHARGER

PORTABLE CHARGER INSTALLATION

WARNING

Use charger ONLY on 48 volt battery systems. Other usage may cause personal injury and damage. Lead acid batteries may generate explosive hydrogen gas during normal operation. Keep sparks, flames, and smoking materials away from batteries. Provide adequate ventilation during charging. Never charge a frozen battery. Study all battery manufacturers' specific precautions such as recommended rates of charge and removing or not removing cell caps while charging.

DANGER

Risk of electric shock. Connect charger power cord to an outlet that has been properly installed and grounded in accordance with all local codes and ordinances. A grounded outlet is required to reduce risk of electric shock – do

not use ground adapters or modify plug. Do not touch uninsulated portion of output connector or uninsulated battery terminal. Disconnect the DC supply before making or breaking the connections to the battery while charging. Do not open or disassemble charger. Do not operate charger if the AC supply cord is damaged or if the charger has received a sharp blow, been dropped, or otherwise damaged in any way – refer all repair work to qualified personnel. Not for use by children.

Portable chargers are shipped with the vehicles. Prior to vehicle or charger operation, the charger **must** be removed and mounted on a platform or wall above the ground to permit maximum air flow around and underneath the charger. **A dedicated circuit is required for the charger.** Refer to the charger manual for appropriate circuit protection. For optimum performance and shortest charge times, place the charger in an area with adequate ventilation. The charger should also be placed in an area that will be relatively free of dirt, mud, or dust since accumulations within the fins of the charger will reduce their heat-dissipating qualities. Optimal cooling also occurs when the charger is placed on a horizontal surface with the fins vertical. More airflow from below the charger will help cool the fins, so placement above open areas or areas with cut-outs for airflow is desirable. If the charger is operated in an outdoor location, rain and sun protection must be provided. The charger may get hot during operation and must be placed such that risk of contact by people is reduced. The charger may be mounted on a wall or shelf using #10-M5 screws. The charger's status display must be visible to the user.



Keep cooling fins clean and free of dirt and debris



NEMA 15 - 5R Grounded AC Receptacle
110 - 120 VAC. Dedicated 15 AMP Circuit

Locations outside the US and Canada: Reference appropriate local electrical code and charger manufacturer recommendations for AC power requirements

Fig. 5 Charger Installation

OPERATION AND SERVICE INFORMATION

Read all of manual to become familiar with this vehicle. Pay attention to all **NOTICES**, **CAUTIONS**, **WARNINGS** and **DANGERS**.

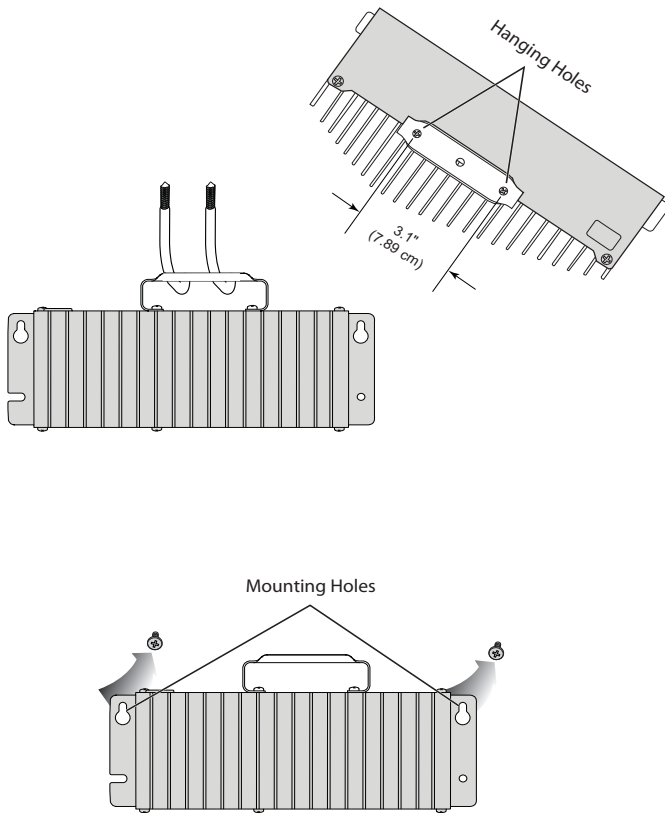

Fig. 6 Charger Mounting

NOTICE

Looping the DC cord through the steering wheel when charging serves as a good reminder to store the cord out of the way when finished with charging. The DC plug can be damaged by driving over or catching the cord on the vehicle when driving away.

WARNING

An ungrounded electrical device may become a physical hazard that could result in an electrical shock or electrocution.

USING THE CHARGER

The charger may remain plugged into the AC outlet when not in use. To charge the vehicle refer to the instruction labels on the charger. Insert the polarized DC plug completely into the vehicle receptacle. The charger will automatically start a few seconds after the plug is in place. The charger will automatically stop when the batteries are fully charged and the DC plug can be removed to permit use of the vehicle.

WARNING

To prevent a physical hazard that could result in an electrical shock or electrocution, be sure that the charger plug is not damaged and is inserted into a grounded receptacle.

The power (AC) cord is equipped with a grounded plug. Do not attempt to pull out, cut or bend the ground post.

The charging (DC) cord is equipped with a polarized connector that fits into a matching receptacle on the vehicle. The receptacle is located on the driver side of the vehicle just below the seat bottom.

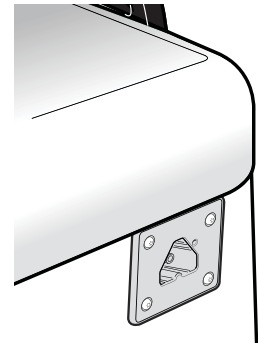

Fig. 7 Charger Receptacle

NOTICE

If vehicle is to be charged with a non E-Z-GO charger, refer to the instructions supplied with the charger.

UNDERSTANDING THE CHARGER

Plugging the charger into the vehicle's charger receptacle will lock the vehicle out of operation. When the charger is plugged into the vehicle's charger receptacle, the charger will automatically turn on and the charger's LED and the vehicle receptacle's LED will start flashing GREEN to indicate the batteries are charging.

Once a minimum battery voltage of 2 volts per cell (Vpc) is reached, the charger's output current will change from a full current charge to the trickle rated charging current. The length of charge time will vary by how depleted the batteries are, the input AC voltage, and/or charger ambient temperatures. The charger's LED will give a SHORT flash if the charge is less than 80% and a LONG flash if the charge is greater than 80%. If the charger's LED is a steady GREEN the batteries are fully charged and the charger may be unplugged, although not necessary. The charger may be left plugged in for long periods of time to maintain the batteries charge level.

If a fault occurred anytime during the charging the charger's LED will quickly flash RED. The specific fault is in-

OPERATION AND SERVICE INFORMATION

Read all of manual to become familiar with this vehicle. Pay attention to all NOTICES, CAUTIONS, WARNINGS and DANGERS.

indicated by the number of RED flashes that occur, there will be a pause and then the flashes will repeat again. There are several possible conditions that will generate errors. Some errors will require human intervention to first resolve the problem and then reset the charger by unplugging the DC cord from the vehicle.

If the AC voltage is interrupted and restored, the charger will turn back on automatically.

LED OPERATION CODES:

SHORT GREEN FLASH = less than 80% charged

LONG GREEN FLASH = more than 80% charged

SOLID GREEN = 100% charged

RED FLASH = fault code

LED FAULT CODES:

RED FLASH: Light turns on briefly, but does not flash after that - check for valid AC voltage.

ONE RED FLASH: One flash, a pause and then again one flash and a pause - Charge Enable Fault: poor contact in the DC connector or dirty contacts or Battery Temperature Fault: battery temperature is greater than 122° F (50° C) or less than 14° F (-10° C).

TWO RED FLASHES: Two flashes, a pause and then again two flashes and a pause - Battery Voltage Fault: Battery pack is less than 36.0 Volts or more than 67.2 Volts. Battery pack is too discharged or over charged for the charger to work.

THREE RED FLASHES: Three flashes, a pause and then again three flashes and a pause - Battery Charge Time-out: Charge time exceeded 24 hours. This may indicate a problem with the battery pack or that the charger output current was severely reduced due to high ambient temperatures.

FOUR RED FLASHES: Four flashes, a pause and then again four flashes and a pause - Battery Fault: Charge time exceeded. This indicates a problem with the battery pack voltage not reaching the required nominal level within the maximum time allowed.

SIX RED FLASHES: Six flashes, a pause and then again six flashes and a pause - Charger Fault: An internal fault has been detected. If this fault is displayed again after unplugging the charger's DC power cord and plugging it back in, the charger must be taken to a qualified service center.

MAINTENANCE INSTRUCTIONS

1. For flooded lead-acid batteries, regularly check the water levels of each battery cell after charging and add distilled water as required to the level specified by the battery manufacturer. Follow the safety instruc-

tions recommended by the battery manufacturer.

2. Make sure the charger connections to the battery terminals are tight and clean. Check for any deformations or cracks in the plastic parts. Check the charger harness for chaffing and rubbing. Inspect all wiring for fraying, loose terminals, chaffing, corrosion or deterioration of the insulation.
3. Keep the cooling fins free of dirt and debris, do not expose the charger to oil, dirt, mud or to direct heavy water spray when cleaning equipment.
4. Inspect the plug of the battery charger and the vehicle receptacle housing for dirt or debris. Clean the DC connector monthly or more often if needed.

NOTICE

If vehicle is to be charged with a non E-Z-GO charger, refer to the instructions supplied with the charger.

Read all of manual to become familiar with this vehicle. Pay attention to all NOTICES, CAUTIONS, WARNINGS and DANGERS.

CONTROLS AND INDICATORS

Vehicle controls and indicators consist of:

1. Key Switch / Direction Selector
2. Speedometer / State Of Charge Meter (optional)
3. Head Light Switch (optional)
4. Turn Signal Switch (optional)
5. Horn Button (optional)
6. Accelerator Pedal
7. Service Brake Pedal
8. Run/Tow Switch

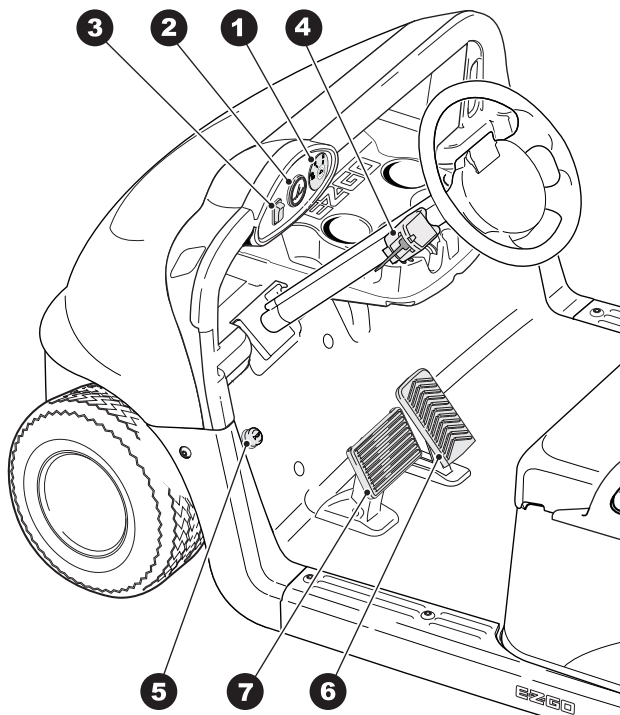

Fig. 8 Operator Controls & Gauges

KEY SWITCH/DIRECTION SELECTOR

Located on the dash panel, the key switch/direction selector (1) enables the electrical system of the vehicle to be turned on and off by turning the key; it also functions as the direction selector for forward, neutral or reverse. To prevent inadvertent operation of the vehicle when left unattended, the key should be turned to the 'OFF' position and removed.



CAUTION

To reduce the possibility of component damage, the vehicle must be stopped before moving the key switch/direction selector.

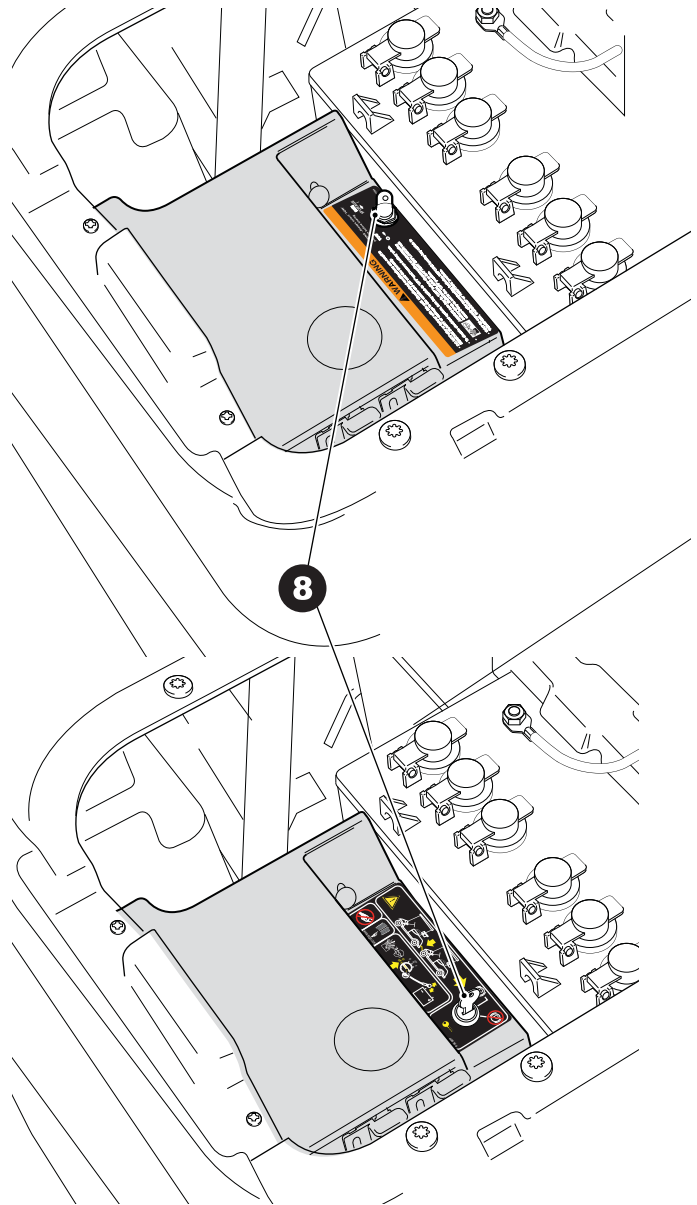

Fig. 9 Run/Tow Switch

SPEEDOMETER / STATE OF CHARGE (SOC) METER (OPTIONAL EQUIPMENT)

If the vehicle is equipped with a speedometer / state of charge meter (2), it is located in the dash panel to the left of the key switch (1) (Ref. Fig. 8). The speedometer displays the MPH, SOC, vehicle mileage, and errors/warnings. The SOC meter indicates the amount of usable power in the batteries. The state of charge meter on the electric vehicle shows the condition of the battery pack with F indicating a full charge on the battery pack and E indicating the battery pack needs to be charged.

OPERATION AND SERVICE INFORMATION

Read all of manual to become familiar with this vehicle. Pay attention to all **NOTICES, CAUTIONS, WARNINGS and DANGERS.**

HEADLIGHT SWITCH (OPTIONAL EQUIPMENT)

If the vehicle is equipped with headlights, the ON/OFF switch (3) is located on the instrument panel to the left of the key switch (1) (Ref. Fig. 8).

TURN SIGNAL SWITCH (OPTIONAL EQUIPMENT)

If the vehicle is equipped with turn signals, the switch (4) is mounted on the steering column (Ref. Fig. 8).

HORN (OPTIONAL EQUIPMENT)

If the vehicle is equipped with a horn, the horn button (5) is located on the driver's side floorboard; depressing the button will sound the vehicle's horn (Ref. Fig. 8).

NOTICE

If the vehicle is equipped with factory installed custom accessories, some accessories remain operational with the key switch in the 'OFF' position.



CAUTION

ALL accessories that do NOT use the accessory wiring harness MUST be connected to draw from the entire 48 Volt battery pack. A DC to DC converter is required for accessories that require voltage other than 48 volts to operate properly.

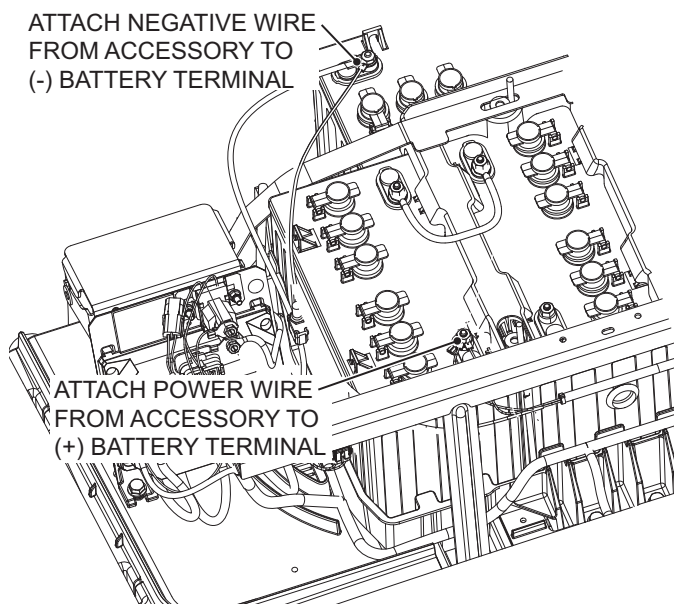

Fig. 10 Attach Accessory Wires to Battery Pack

Accessories, including a DC to DC converter, that are connected to this vehicle and do not use the accessory

harness must be connected across the entire 48 volt battery pack. This can be done by connecting to the two battery terminals shown in the illustration.(Ref. Fig. 10) If the accessory requires voltage other than 48 volts a DC to DC converter must be used to change the voltage to the amount required by the accessory. A DC to DC converter is available through E-Z-GO Service Parts.

The Operational Performance Guarantee of 2 rounds per day shall be void if non-factory accessories that use more than 1 Amp/Hour of energy per round are installed on the vehicle.

ACCELERATOR & BRAKE PEDALS

With the key switch in the 'F' or 'R' position, depressing the accelerator pedal (6) starts the motor and will move the vehicle in the direction indicated on the key switch/direction selector. This vehicle is equipped with a motor brake; when the accelerator pedal is released, the motor will stop. To stop the vehicle more quickly, depress the service brake pedal (7)(Ref. Fig. 8).

RUN/TOW SWITCH



CAUTION

Before attempting to tow the vehicle, turn the key switch to 'N' and move the Run/Tow switch to the 'TOW' position. Failure to do so will damage the controller or motor.

NOTICE

The RUN/TOW switch should always be returned to the 'RUN/STORAGE' or Ⓟ (on European Models) position after towing the vehicle. If the switch is left in the 'TOW' or Ⓡ (on European Models) position for an extended period of time it will drain the batteries.

The run/tow switch (8) is located under the seat on the passenger side of the vehicle (Ref. Fig. 9).

With the switch in the 'TOW' or Ⓡ (on European Models) position and the key in 'N':

- the electronic parking brake is deactivated, which allows the vehicle to be towed or roll freely, except in the event of a controller failure
- the service brake is still active
- the reverse warning beeper is deactivated

With the switch in 'RUN/STORAGE' or Ⓟ (on European Models) position:

- the electronic parking brake is deactivated and the reverse warning beeper features are activated

OPERATION AND SERVICE INFORMATION

Read all of manual to become familiar with this vehicle. Pay attention to all NOTICES, CAUTIONS, WARNINGS and DANGERS.

PARKING BRAKE

This vehicle is equipped with an automatic parking brake; when the vehicle is stopped the parking brake is automatically set. The parking brake is released when the key switch/direction selector is in forward ('F') or reverse ('R') and the accelerator is depressed. The parking brake is also released when the run/tow switch is placed in the 'TOW' or  (on European Models) position with the key switch turned to neutral ('N').

In the event that the vehicle will not move in forward or reverse, the parking brake can be released using the instructions located on the controller splash shield beneath the seat on the passenger side of the vehicle. To move the vehicle, turn the key switch to 'N', flip the RUN-TOW switch to the 'TOW' position, move the vehicle to a safe location on level ground, chock the tires, and turn the key to 'OFF'.

In case of total power loss and the RUN-TOW switch does not release the parking brake the instructions below the controller splash shield must be used. Chock the tires to prevent the vehicle moving when the brake is released.

To access the instructions remove three re-usable plastic rivets securing the controller splash shield to the body and the controller. To remove the re-usable rivets, press the center of the rivet with the vehicle key. When the center pin snaps into place the rivet can be removed. Repeat the process for each remaining rivet. Turn the splash shield over to reveal the instructions for releasing the parking brake.



WARNING

THIS PROCEDURE SHOULD ONLY BE PERFORMED BY QUALIFIED TRAINED PERSONNEL.

Make sure that the key is in the 'OFF' position and the tires are chocked to prevent the vehicle moving; then perform the following:

1. Locate the 'Auxiliary Power' line (3) and remove the weather pack seal (4) from the connector.
2. Locate the 'Primary Power' line connector (1) and disconnect it from line (2).
3. Connect the 'Auxiliary Power' line (3) to the 'Primary Power' line (1) which will release the brake. If the tires

are not chocked and the vehicle is not on flat ground the vehicle will move immediately.

4. Move the vehicle to desired, safe location and chock the tires immediately.
5. Disconnect the 'Auxiliary Power' line (3) from the 'Primary Power' line (1).
6. Connect the 'Primary Power' line (1) to line (2).
7. Replace the weather pack seal (4) on the 'Auxiliary Power' line connector (3).

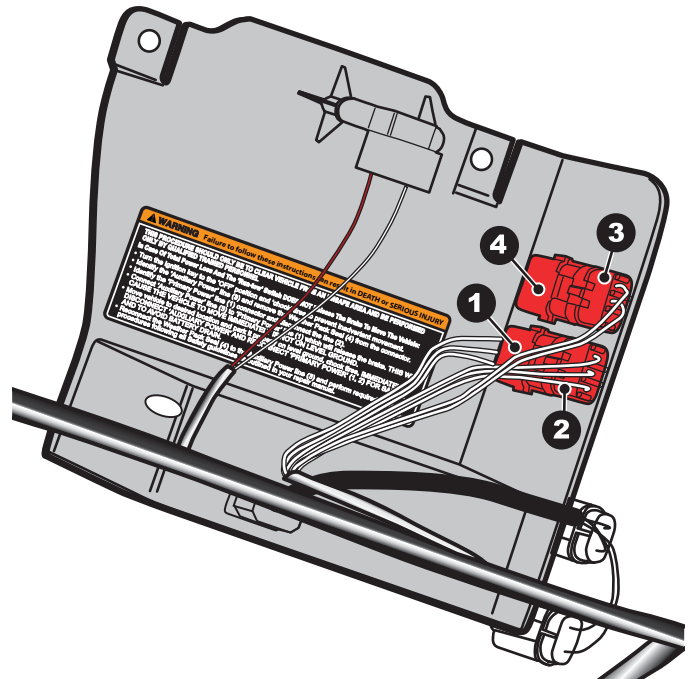

Fig. 11 Splash Shield and Parking Brake Release

To reinstall the controller splash shield, position the splash shield by aligning the mounting holes with the holes in the body, push the center pin of each rivet upward so that the top of the pin is above the rivet head. Place a rivet in each mounting hole of the controller splash shield and push down on the center pin until the top of the pin is flush with the rivet head.



OPERATION AND SERVICE INFORMATION

Read all of manual to become familiar with this vehicle. Pay attention to all NOTICES, CAUTIONS, WARNINGS and DANGERS.

OPERATING THE VEHICLE



CAUTION

Improper use of the vehicle or the lack of proper maintenance may result in damage or decreased performance.

Read the following warnings before attempting to operate the vehicle.



WARNING

To reduce the possibility of severe injury or death resulting from loss of vehicle control, the following warnings must be observed:

When driving vehicle, consider the terrain, traffic conditions and the environmental factors which effect the terrain and the ability to control the vehicle.

Use extra care and reduced speed when driving on poor surfaces, such as loose dirt, wet grass, gravel, etc.

Stay in designated areas and avoid extremely rough terrain.

Maintain a safe speed when driving down hill. Use the service brake to reduce speed when traveling down an incline. A sudden stop or change of direction may result in loss of control.

Slow down before and during turns. All turns should be made at reduced speed.

Never drive vehicle up, down, or across an incline that exceeds 14° (25% grade).



WARNING

To reduce the possibility of severe injury or death resulting from improper vehicle operation, the following warnings must be observed:

Refer to GENERAL SPECIFICATIONS for seating capacity.

To prevent inadvertent movement when the vehicle is to be left unattended, turn key to 'OFF' position and remove the key.

Make sure that the direction selector is in correct position before attempting to start the

vehicle.

Always bring the vehicle to a complete stop before shifting the direction selector.

Check the area behind the vehicle before operating in reverse.

All occupants must be seated. Keep entire body inside vehicle and hold on while vehicle is in motion.

REGENERATIVE BRAKING



WARNING

To prevent the possibility of loss of control that could cause severe injury or death, use service brake to reduce speed.

This vehicle is equipped with a regenerative motor control system.

Example: If both of the following events occur:

- the vehicle is being driven down a slope
- the driver attempts to exceed the specified top speed with the accelerator pedal depressed or released

the regenerative braking will limit the speed of the vehicle to the specified top speed. When the regenerative braking system is activated by this sequence of events, the motor generates power that is returned to the batteries.

When the vehicle speed is reduced below the maximum by using the service brake, the speed will not increase unless the throttle is increased. When the brake pedal is released the vehicle will slow down as it does with pedal up braking.

PEDAL-UP BRAKING

Pedal-up braking is regenerative braking that occurs when the accelerator pedal is released while the vehicle is moving.

Example: If both of the following events occur:

- the vehicle is being driven down a slope
- the accelerator pedal is released

the pedal-up braking will slow the vehicle until the vehicle stops, or the accelerator pedal is applied. When pedal-up braking system is activated by this sequence of events, the motor generates power that is returned to the batteries.

Read all of manual to become familiar with this vehicle. Pay attention to all NOTICES, CAUTIONS, WARNINGS and DANGERS.

HIGH PEDAL DISABLE FEATURE

High pedal disable prevents acceleration if the key is turned on while the accelerator is depressed.

STARTING AND DRIVING

All vehicles are equipped with an interlock system that disables the controller and prevents the vehicle from being operated or towed while the charger is connected. Remove the charger plug from the vehicle receptacle and properly store the cable prior to moving the vehicle.

To operate the vehicle:

- Place the key in the key switch and turn it to the 'ON'/'N' position.
- Move the direction selector to the direction desired.
- Slowly depress the accelerator pedal to start the motor.
- When the accelerator pedal is released, the motor controls the deceleration. To stop the vehicle more quickly, depress the **service brake pedal**.

NOTICE

When the direction selector is in the reverse position, a warning signal will sound to indicate that the vehicle is ready to run in reverse.

STARTING VEHICLE ON A HILL

The parking brake will activate automatically when the vehicle comes to a stop. To start the vehicle on a hill depress the accelerator pedal and the parking brake will be released.

COASTING

Uncontrolled coasting does not occur with this model. However, this is not a substitute for the service brake which should be used to slow the speed of the vehicle quickly.

NOTICE

This model is equipped with a feature (pedal-up braking) that slows the vehicle's speed when the accelerator pedal is released until the vehicle stops.

LABELS AND PICTOGRAMS

Vehicles may be labeled with pictograms as a method of conveying information or warnings. The Vehicle Label Identification Section of this manual explains the labels that are used on this vehicle.

SUN TOP AND WINDSHIELD

WARNING

The sun top does not provide protection from roll-over or falling objects.

The windshield does not provide protection from tree limbs or flying objects.

The sun top and windshield provide some protection from the elements; however, they will not keep the operator and passenger dry in a downpour. This vehicle is not equipped with seat belts and the sun top has not been designed to provide roll-over protection. In addition, the sun top does not protect against falling objects nor does the windshield protect against flying objects and tree limbs. Keep arms and legs inside of the vehicle while it is moving.

OPERATION AND SERVICE INFORMATION

Read all of manual to become familiar with this vehicle. Pay attention to all NOTICES, CAUTIONS, WARNINGS and DANGERS.

VEHICLE CLEANING AND CARE

VEHICLE CLEANING

WARNING

To reduce the possibility of severe injury or vehicle damage, read all instructions supplied by the manufacturer of the pressure washer.

CAUTION

When pressure washing the exterior of the vehicle, do not use pressure in excess of 700 psi. To reduce the possibility of cosmetic damage, do not use any abrasive or reactive solvents to clean plastic parts.

It is important that proper techniques and cleaning materials be used. Using excessive water pressure may cause severe injury to the operator or bystander, damage to the seals, plastics, seat material, body finish or electrical system. Do not use pressure in excess of 700 psi to wash the exterior of the vehicle.

Clean the windshield with lots of water, a mild soap and a clean cloth.

Normal cleaning of vinyl seats and plastic or rubber trim requires the use of a mild soap solution applied with a sponge or soft brush and wiped with a damp cloth.

Removal of oil, tar, asphalt, shoe polish, etc., requires the use of a commercially available vinyl/rubber cleaner.

The painted surfaces of the vehicle provide attractive appearance and durable protection. Frequent washing with lukewarm or cold water and mild detergent is required to preserve the painted surfaces.

Occasional cleaning and waxing with non-abrasive products designed for 'clear coat' automotive finishes will enhance the appearance and durability of the painted surfaces.

Corrosive materials used as fertilizers or for dust control can collect on the underbody of the vehicle. These materials will cause corrosion of underbody parts unless flushed occasionally with plain water. Thoroughly clean any areas where mud or other debris can collect. Sediment packed in closed areas should be loosened to ease its removal, taking care not to chip or otherwise damage paint.

REPAIR

LIFTING THE VEHICLE

Tool List	Qty.
Floor Jack	1
Jack Stands	4
Wheel Chocks.....	4
Some servicing operations may require the front wheels, the rear wheels, or the entire vehicle be raised.	

WARNING

To reduce the possibility of severe injury or death from a vehicle falling from a jack:

Be sure the vehicle is on a firm and level surface.

Never get under a vehicle while it is supported by a jack.

Use jack stands and test the stability of the vehicle on the stands.

Always place chocks in front and behind the wheels not being raised.

Use extreme care since the vehicle is extremely unstable during the lifting process.

CAUTION

When lifting the vehicle, position the jacks and jack stands at the areas indicated only.

To raise the entire vehicle, install the wheel chocks in front and behind each front wheel. Center the jack under the bagwell and place a piece of wood, approximately 2" x 4" x 12", between the jack and the underside of the bagwell. Raise the vehicle and position the jack stands under the frame where the leaf spring mounting bracket is welded to the frame.(Ref. Fig. 13)

Lower the jack and test the stability of the vehicle on the two jack stands.

Place the jack under the center front of the car just behind the bumper. Raise the vehicle and position the jack stands under the frame where the instrument panel support is attached to the frame.(Ref. Fig. 13)

Lower the jack and test the stability of the vehicle on all four jack stands.

To raise only the front or rear of the vehicle, place the wheel chocks in front and behind the wheels that are not to be raised. The jack may be left under the center front

Read all of manual to become familiar with this vehicle. Pay attention to all **NOTICES, CAUTIONS, WARNINGS and DANGERS.**

of the frame while the front end of the vehicle is on the jack stands.

Lower the vehicle by reversing the lifting sequence.

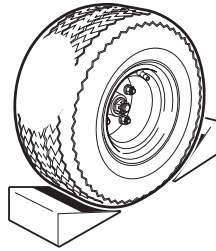

Fig. 12 Chock Wheels

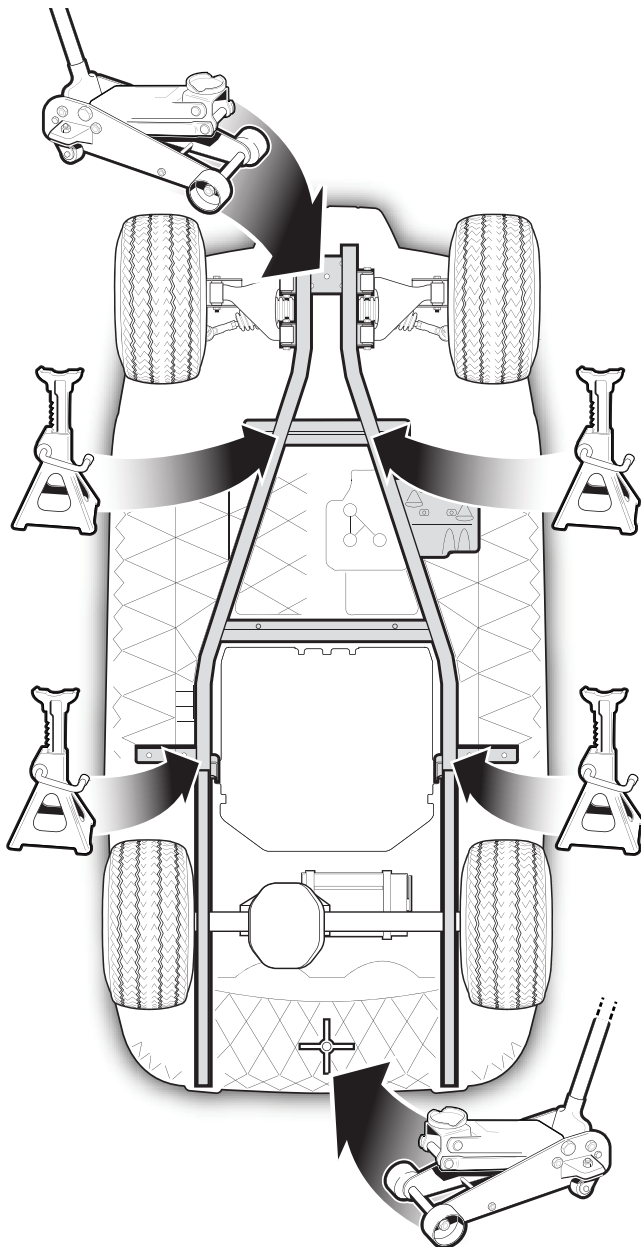

Fig. 13 Lifting the Vehicle

WHEELS AND TIRES

TIRE REPAIR

Tool List

	Qty.
Lug Wrench, 3/4"	1
Impact Socket, 3/4"	1
Impact Wrench.....	1
Torque Wrench, ft. lbs.....	1

WARNING

A tire explosion can cause severe injury or death. Never exceed the inflation pressure rating on the tire sidewall.

To reduce the possibility of tire explosion, pressurize tire with small amount of air applied intermittently to seat beads. Due to the low volume of the small tires, overinflation can occur in seconds. Never exceed the tire manufacturer's recommendation when seating a bead. Protect face and eyes from escaping air when removing a valve core.

To reduce the possibility of severe injury caused by a broken socket when removing wheels, use only sockets designed for impact wrench use.

Use caution when inflating tires. Overinflation could cause the tire to separate from the wheel or cause the tire to explode, either of which could cause severe injury.

DO NOT use low inflation tires on any E-Z-GO vehicle. DO NOT use any tire which has a recommended inflation pressure less than the inflation pressure recommended in the owner's guide.

Use caution when inflating tires. Due to the low volume of the small tires, overinflation can occur in seconds. Overinflation could cause the tire to separate from the wheel or cause the tire to explode.

*Tire inflation should be determined by the condition of the terrain. See GENERAL SPECIFICATIONS section for recommended tire inflation pressure. For outdoor applications with major use on grassy areas, the following should be considered. On hard turf, it is desirable to have a **slightly** higher inflation pressure. On very soft turf, a lower pressure reduces the possibility of tires cutting into the turf. For vehicles being used on paved or hard surfaces, tire inflation pressure should be in the higher allowable range, but under no condition should inflation*

OPERATION AND SERVICE INFORMATION

Read all of manual to become familiar with this vehicle. Pay attention to all **NOTICES**, **CAUTIONS**, **WARNINGS** and **DANGERS**.

pressure be higher than recommended on tire sidewall. **All four tires** should have the same pressure for optimum handling characteristics. Be sure to install the valve stem dust cap after checking or inflating.

The vehicle is fitted with low pressure tubeless tires mounted on one piece rims; therefore, the most cost effective way to repair a puncture in the tread is to use a commercial tire plug.

NOTICE

Tire plug tools and plugs are available at most automotive parts outlets and have the advantage of not requiring the tire be removed from the wheel.

If the tire is flat, remove the wheel and inflate the tire to the maximum recommended pressure for the tire. Immerse the tire in water to locate the leak and mark with chalk. Insert tire plug in accordance with manufacturer's instructions

! WARNING

To reduce the possibility of severe injury, be sure the mounting/demounting machine is anchored to floor. Wear OSHA approved safety equipment when mounting/demounting tires.

If the tire is to be removed or mounted, the tire changing machine manufacturer's recommendations must be followed in order to reduce possibility of severe injury.

WHEEL INSTALLATION

! CAUTION

To reduce the possibility of component damage, do not tighten lug nuts to more than 85 ft. lbs. (115 Nm) torque.

NOTICE

It is important to follow the 'cross sequence' pattern when installing lug nuts. This will assure even seating of the wheel against the hub.

With the valve stem to the outside, mount the wheel onto the hub with lug nuts. Finger tighten the lug nuts (1) in a 'cross sequence' pattern (Ref. Fig. 14). Tighten the lug nuts to 50 - 85 ft. lbs. (70 - 115 Nm) torque in 20 ft. lbs. (30 Nm) increments following the 'cross sequence' pattern.

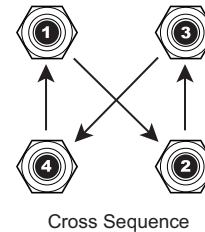
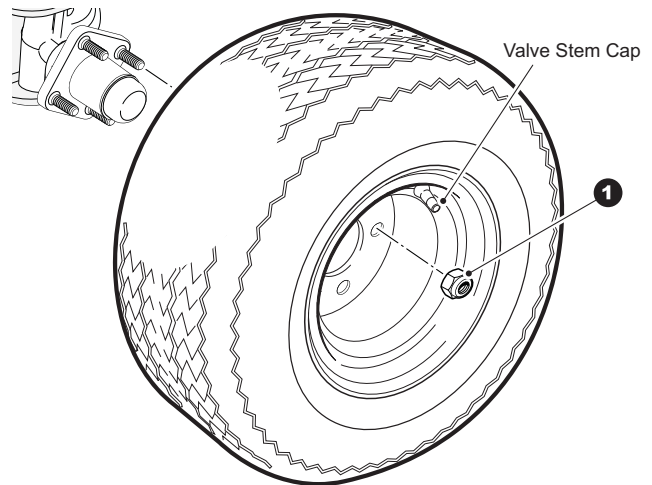

Fig. 14 Wheel Installation

LIGHT BULB REPLACEMENT

! CAUTION

To reduce the possibility of premature bulb failure, do not touch new bulbs with bare fingers. Use clean, dry tissue or paper towel to handle the glass portion of the bulb.

HEAD LIGHT BULB REPLACEMENT

Make sure that the vehicle key switch is in the 'OFF' position and the key has been removed. For vehicles equipped with lights mounted in the cowl locate the headlight bulb socket on the backside of the light assembly.

1. Disconnect the accessory harness (5) from the light bulb.
2. Turn the headlight bulb (3) clockwise and pull to remove.

OPERATION AND SERVICE INFORMATION

Read all of manual to become familiar with this vehicle. Pay attention to all **NOTICES, CAUTIONS, WARNINGS and DANGERS.**

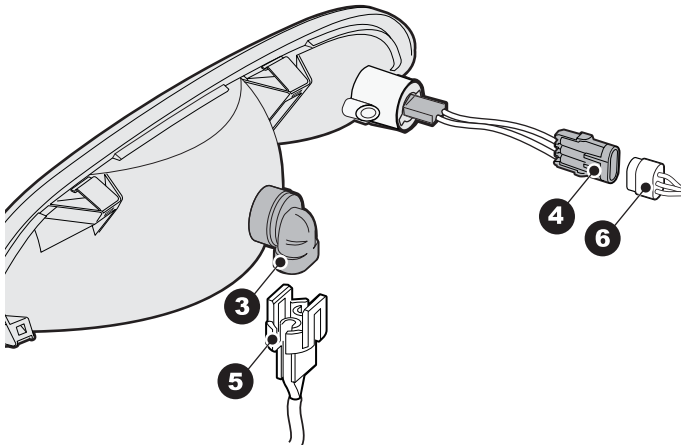

Fig. 15 Headlight Bulb Replacement

3. Align the bulb with the opening in the back of the headlight assembly.
4. Turn the bulb (3) counter clockwise until it stops.
5. Connect the accessory harness (5) to the light bulb (3).

TURN SIGNAL BULB REPLACEMENT

Make sure that the vehicle key switch is in the 'OFF' position and the key has been removed.

1. Remove the phillips head screw (7) and turn the retaining collar (8) to align with the turn signal bulb housing (9).
2. Grip the turn signal bulb housing (9) and pull backward to remove housing from the headlight assembly.

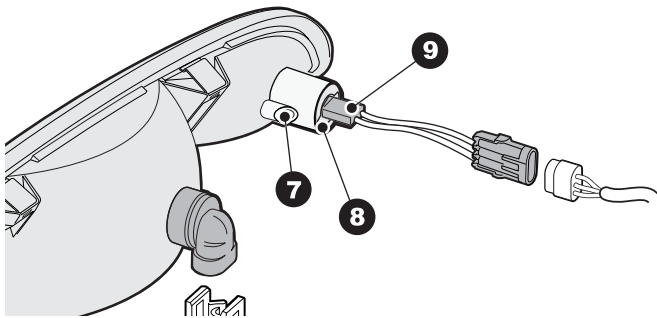

Fig. 16 Turn Signal Bulb Replacement

3. Remove the bulb from the housing and replace with a new one.
4. Push turn signal housing (9) into headlight assembly firmly, making sure that it is seated completely.
5. Turn the retaining collar (8) to secure the bulb housing and install the phillips head screw (7) to secure in place.

TAILLIGHT/BRAKE LIGHT BULB REPLACEMENT

Make sure that the vehicle key switch is in the 'OFF' position and the key has been removed.

1. Remove the two phillips head screws (10) that secure the lens (11) to the taillight assembly.
2. Remove the light bulb.
3. Install the new light bulb.
4. Install the lens (11) and secure in place with the two phillips head screws. (10)

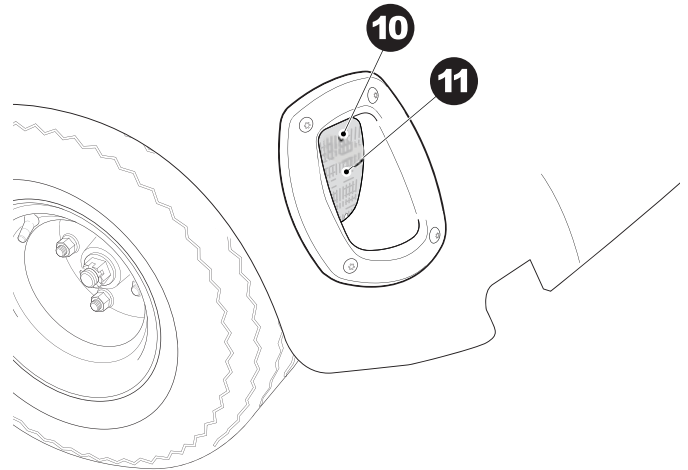

Fig. 17 Tail and Brake Light Bulb Replacement

TRANSPORTING VEHICLE

TOWING

WARNING

To reduce the possibility of severe injury or death:

Use extra caution when towing a vehicle.

DO NOT ride on the vehicle being towed.

DO NOT attempt to tow the vehicle with ropes, chains or any device other than a factory approved tow bar.

DO NOT tow the vehicle on highways.

DO NOT tow a single vehicle at speeds in excess of 12 mph (19 kph).

DO NOT tow more than three vehicles at a time.

OPERATION AND SERVICE INFORMATION

Read all of manual to become familiar with this vehicle. Pay attention to all NOTICES, CAUTIONS, WARNINGS and DANGERS.

DO NOT exceed 5 mph (8 kph) while towing multiple vehicles.



CAUTION



Place key switch in 'N' and the Run/Tow switch in the 'TOW' or  (on European Models) position prior to towing the vehicle to prevent damage to the electric motor and controller.

Do not tow a single vehicle at speeds in excess of 12 mph (19 kph). Do not tow more than three vehicles at a time. Do not exceed 5 mph (8 kph) while towing multiple vehicles. Towing the vehicle above the recommended speed may result in severe injury and/or damage to the vehicle and other property.

Tow bars are not intended for road use.

NOTICE

If a vehicle is towed in excess of 15 mph the motor brake will engage and slow the vehicle down.

This vehicle is equipped with a 'Run/Tow' switch located underneath the seat on the passenger side. The 'TOW' or  (on European Models) position, with the key switch in the 'N' position, allows the vehicle to roll freely without activating the warning beeper and eliminating potential damage to controller or motor. Check to see that vehicles to be towed are switched to the 'TOW' or  (on European Models) position and the key is turned to the neutral ('N') position. Always return the switch to the 'RUN/STORAGE' or  (on European Models) position after moving the vehicle and make sure that the key switch is turned to 'OFF' and the key removed.

Never use ropes or chains to tow vehicle(s). Tow bars are available from the E-Z-GO Service Parts Department.

Tow bars are not intended for highway use. Before towing, place the direction selector in neutral (N) and make sure that the 'Run/Tow' switch in 'TOW' or  (on European Models). Do not ride on a vehicle being towed. Tow bars are designed to tow only one vehicle at a maximum speed of 12 mph (19 kph) and up to three vehicles at a maximum speed of 5 mph (8 kph).

In the event that there is no power through the controller to release the parking brake with the vehicle in the 'TOW' or  (on European Models) mode, the vehicle can still be moved by using the procedure described under PARKING BRAKE. See "PARKING BRAKE" on page 7.

HAULING



WARNING

To reduce the possibility of severe injury or death while transporting the vehicle:

Secure the vehicle and contents.

Never ride on the vehicle being transported.

Always remove the windshield before transporting.

Maximum speed with sun top installed is 50 mph (80 kph).

If the vehicle is to be transported at highway speeds, the sun top must be removed and the seat bottom secured. When transporting vehicle below highway speeds, check for tightness of hardware and cracks in sun top at mounting points. Always remove windshield when transporting. Always check that the vehicle and contents are adequately secured before transporting. The rated capacity of the trailer or truck must exceed the weight of the vehicle (see GENERAL SPECIFICATIONS for vehicle weight) and load plus 1000 lbs. (454 kg). Secure the vehicle using ratchet tie downs.

Read all of manual to become familiar with this vehicle. Pay attention to all **NOTICES, CAUTIONS, WARNINGS and DANGERS.**

SERVICE AND MAINTENANCE

WARNING

To reduce the possibility of severe injury or death from improper servicing techniques:

DO NOT attempt any type of servicing operations before reading all notes, cautions and warnings in this manual.

Any servicing requiring adjustments to be made to the powertrain while the motor is running must be made with both drive wheels raised and vehicle properly supported on jack stands.

To reduce the possibility of motor damage, never operate vehicle at full throttle for more than 4 - 5 seconds while vehicle is in a 'no load' condition.



Wear eye protection when working on the vehicle. Use extra care when working around batteries, or using solvents or compressed air.

To reduce the possibility of causing an electrical arc, which could result in a battery explosion, turn off all electrical loads from the battery before removing battery wires.



Wrap wrenches with vinyl tape to reduce the possibility of a dropped wrench 'shorting out' a battery, which could result in an explosion.

The electrolyte in a battery is an acid solution which can cause severe burns to the skin and eyes. Treat all electrolyte spills to the body and eyes with extended flushing with clear water. Contact a physician immediately.

Any electrolyte spills should be neutralized with a solution of 2 teaspoons (10 ml) sodium bicarbonate (baking soda) dissolved in 1 quart (1 liters) of water and flushed with water.

Aerosol containers of battery terminal protectant must be used with extreme care. Insulate metal container to reduce the pos-

sibility of can contacting battery terminals which could result in an explosion.

It is in the best interest of both vehicle owner and service technician to carefully follow the procedures recommended in this manual. Preventative maintenance, applied at recommended intervals, is the best guarantee for keeping the vehicle both dependable and economical.

This vehicle will give years of satisfactory service, providing it receives regular maintenance. Refer to the Periodic Service Schedule for appropriate service intervals (Ref. Fig. 21).

ROUTINE MAINTENANCE

CAUTION

To prolong vehicle life, some maintenance items must be serviced more frequently on vehicles used under severe driving conditions such as extreme temperatures, extreme dust/debris conditions, frequent use with maximum load.

To access the powertrain for routine maintenance, lift or remove the seat and remove the rear access panel. For major repair, refer to the appropriate Technician's Repair and Service Manual.

Some service procedures may require the vehicle to be lifted. Refer to **LIFTING THE VEHICLE** for proper lifting procedure and safety information.

TIRE INSPECTION

Tire condition should be inspected per the Periodic Service Schedule. Inflation pressures should be checked when the tires are cool. Be sure to install the valve dust cap after checking or inflating.

REAR AXLE

The only maintenance required for the first five years is the periodic inspection of the rear axle for lubricant leakage. Unless leakage is evident, the lubricant need only be replaced after five years. Refer to the Service & Repair Manual p/n 605975 for the fluid replacement procedure.

HARDWARE

Periodically, the vehicle should be inspected for loose fasteners. Fasteners should be tightened in accordance with the Torque Specifications table (Ref. Fig. 20).

OPERATION AND SERVICE INFORMATION

Read all of manual to become familiar with this vehicle. Pay attention to all **NOTICES, CAUTIONS, WARNINGS and DANGERS.**

Use care when tightening fasteners and refer to the Technician's Repair and Service Manual for specific torque values.

Generally, three classes of standard hardware and two classes of metric hardware are used in the vehicle. Grade 5 hardware can be identified by the three marks on the hexagonal head and grade 8 hardware is identified by 6 marks on the head. Metric hardware is marked on the head with 8.8 or 10.9. Unmarked hardware is Grade 2.

CAPACITIES AND REPLACEMENT PARTS

FLUID	PART NUMBER	QTY
Rear Axle Lubricant Mobilube 85W - 140	613175	25 oz. (651 ml)
Friction Modifier E-Z-GO	611242	2 oz. (59 ml)

Fig. 18 Capacities

ITEM	PART NUMBER
Fuse	ATC 10A (E-Z-GO P/N 35212G07)
Headlight Bulb	894 (E-Z-GO P/N 74004G01)
Turn Signal Bulb	912-NA (E-Z-GO P/N 74005G01)
Tail Light Bulb	2057 (E-Z-GO P/N 604311)

Fig. 19 Replacement Part







ALL TORQUE FIGURES ARE IN FT. LBS. (Nm)										
Unless otherwise noted in text, tighten all hardware in accordance with this chart.										
This chart specifies 'lubricated' torque figures. Fasteners that are plated or lubricated when installed are considered 'wet' and require approximately 80% of the torque required for 'dry' fasteners.										
BOLT SIZE	1/4"	5/16"	3/8"	7/16"	1/2"	9/16"	5/8"	3/4"	7/8"	1"
Grade 2 	4 (5)	8 (11)	15 (20)	24 (33)	35 (47)	55 (75)	75 (102)	130 (176)	125 (169)	190 (258)
Grade 5 	6 (8)	13 (18)	23 (31)	35 (47)	55 (75)	80 (108)	110 (149)	200 (271)	320 (434)	480 (651)
Grade 8 	6 (8)	18 (24)	35 (47)	55 (75)	80 (108)	110 (149)	170 (230)	280 (380)	460 (624)	680 (922)
BOLT SIZE	M4	M5	M6	M8	M10	M12	M14			
Class 5.8 (Grade 2) 	1 (2)	2 (3)	4 (6)	10 (14)	20 (27)	35 (47)	55 (76.4)			
Class 8.8 (Grade 5) 	2 (3)	4 (6)	7 (10)	18 (24)	35 (47)	61 (83)	97 (131)			
Class 10.9 (Grade 8) 	3 (4)	6 (8)	10 (14)	25 (34)	49 (66)	86 (117)	136 (184)			

Fig. 20 Torque Specifications and Bolt Grades

OPERATION AND SERVICE INFORMATION

Read all of manual to become familiar with this vehicle. Pay attention to all NOTICES, CAUTIONS, WARNINGS and DANGERS.

PERIODIC SERVICE SCHEDULE

✓ - CHECK **C&A** - CHECK & ADJUST **CL** - CLEAN **R** - REPLACE

REMARKS	before each use DAILY	20 rnds/20 hrs 100 miles/160 kms	60 rnds/60 hrs 300 miles/500 kms	125 rnds/125 hrs 600miles/1000 kms	250 rnds/250 hrs 1200miles/2000 kms	5 YEARS	PAGE
Tires - pressure, condition of tires & rims	✓	✓	✓	✓	✓		9
Hardware - loose or missing	✓	✓	✓	✓	✓		
Reverse Warning Indicator	✓	✓	✓	✓	✓		
Overall Vehicle Condition	✓	✓	✓	✓	✓		
Batteries - state of charge, condition, loose terminals, corrosion, hold down & hardware	✓	✓	CL	CL	CL		17
Batteries* - check electrolyte level, fill if required		C&A	C&A	C&A	C&A		18
Brakes - smooth operation of pedal, stopping distance	✓	✓	✓	✓	✓		
Brakes - aggressive stop test, does brake hold on a hill		✓	✓	✓	✓		
Accelerator - smooth operation	✓	✓	✓	✓	✓		
Wiring - loose connections, broken or missing insulation		✓	✓	✓	✓		
Charger Receptacle - clean connections		CL	CL	CL	CL		
Steering Assembly - excessive play, loose or missing hardware		✓	✓	✓	✓		
Tie Rods - excessive play, bent rods, loose or missing hardware		✓	✓	✓	✓		14
Rear Axle - fluid level, oil leakage, noise, loose or missing hardware		✓	✓	✓	✓		14
Rear Axle - drain & replace fluid						R	
Front Suspension - strut oil leakage, excessive play in hubs or kingpins, worn bushings, loose or missing hardware		✓	✓	✓	✓		
Front Wheel Alignment - unusual tire wear			C&A	C&A	C&A		
Rear Susspension - shock oil leakage,worn bushings, loose or missing hardware			✓	✓	✓		
Motor Coupling - Add Anti - Sieze compound (Approx 1 tablespoon)						20,000 AMP- Hrs	

Fig. 21 Periodic Service Schedule

*Use only distilled or purified water that is free of contaminants to fill batteries.

OPERATION AND SERVICE INFORMATION

Read all of manual to become familiar with this vehicle. Pay attention to all **NOTICES**, **CAUTIONS**, **WARNINGS** and **DANGERS**.

BATTERIES AND CHARGING

SAFETY

NOTICE

Always observe the following warnings when working on or near batteries:

WARNING

To prevent battery explosion that could result in severe personal injury or death, keep all smoking materials, open flames or sparks away from the batteries.

Hydrogen gas is formed when charging batteries. Do not charge batteries without adequate ventilation. A 4% concentration of hydrogen gas is explosive.

Be sure that the key switch is off and all electrical accessories are turned off before starting work on the vehicle.

Never disconnect a circuit under load at a battery terminal.

SAFETY FIRST



**BEND KNEES
WHEN
LIFTING**

Batteries are heavy. Use proper lifting techniques when moving them.

Always lift the battery with a commercially available battery lifting device.

Use care not to tip batteries when removing or installing them; spilled electrolyte can cause burns and damage.

The electrolyte in a storage battery is an acid solution which can cause severe burns to the skin and eyes. Treat all electrolyte spills to the body and eyes with extended flushing with clear water. Contact a physician immediately.



Always wear a safety shield or approved safety goggles when adding water or charging batteries.

Any electrolyte spills should be neutralized with a solution of 1/4 cup (60 ml) sodium bicarbonate (baking soda) dissolved in 1 1/2 gallons (6 liters) of water and flushed with

water.

Overfilling batteries may result in electrolyte being spilled from the battery during the charge cycle. Expelled electrolyte may cause damage to the vehicle and storage facility.

Aerosol containers of battery terminal protectant must be used with extreme care. Insulate metal container to prevent can from contacting battery terminals which could result in an explosion.

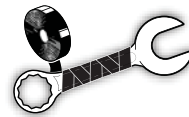

Wrap wrenches with vinyl tape to prevent the possibility of a dropped wrench from 'shorting out' a battery, which could result in an explosion and severe personal injury or death.

BATTERY

A battery is defined as two dissimilar metals immersed in an acid. If the acid is absent or if the metals are not dissimilar, a battery has not been created. The batteries most commonly used in these vehicles are lead acid.

A battery does not store electricity, but is able to produce electricity as the result of a chemical reaction which releases stored chemical energy in the form of electrical energy. The chemical reaction takes place faster in warm conditions and slower in cold conditions. Temperature is important when conducting tests on a battery and test results must be corrected to compensate for temperature differences.

As a battery ages, it still performs adequately except that its **capacity** is diminished. Capacity describes the time that a battery can continue to provide its design amperes from a full charge.

A battery has a maximum life, therefore good maintenance is designed to maximize the **available** life and reduce the factors that can reduce the life of the battery.

Read all of manual to become familiar with this vehicle. Pay attention to all **NOTICES, CAUTIONS, WARNINGS and DANGERS.**

BATTERY MAINTENANCE

Tool List	Qty.
Insulated Wrench, 9/16"	1
Battery Carrier	1
Hydrometer.....	1
Battery Maintenance Kit P/N 25587-G01	1

AT EACH CHARGING CYCLE

! WARNING

To reduce the possibility of fire, never attach a battery charger to a vehicle that is to be unattended beyond the normal charging cycle. Overcharging could cause damage to the vehicle batteries and result in extreme overheating. The charger should be checked after 24 hours and unplugged after the charge cycle is complete.

Before charging the batteries, inspect the plug of the battery charger and vehicle receptacle housing for dirt or debris.

Charge the batteries after each day's use.

MONTHLY

- Inspect all wiring for fraying, loose terminations, corrosion or deterioration of insulation.
- Check that the electrolyte level is correct and add suitable water as required.
- Clean the batteries and wire terminations.
- Coat battery terminals with commercially available protectant.

ELECTROLYTE LEVEL AND WATER

The correct level of the electrolyte is 1/2" (13 mm) above the plates in each cell.

This level will leave approximately 1/4" - 3/8" (6 - 10 mm) of space between the electrolyte and the vent tube. The electrolyte level is important since any portion of the plates exposed to air will be ruined beyond repair. Also avoid filling with too much water, which will result in electrolyte being forced out of the battery due to gassing and a decrease in volume of the electrolyte that results from the charging cycle.

! CAUTION

DO NOT overfill batteries. The charging cycle will expel electrolyte and result in component damage

A battery being charged will 'gas' with the majority of the gassing taking place at the end of the charging cycle. This gas is hydrogen which is lighter than air. Water and sulfuric acid droplets will be carried out of the battery vents by the hydrogen gas, however, this loss is minimal. If the battery electrolyte level is too high, the electrolyte will block the vent tube and the gas will force it out of the vent tube and battery cap. The water will evaporate but the sulfuric acid will remain where it can damage vehicle components and the storage facility floor. Sulfuric acid loss will weaken the concentration of acid within the electrolyte and reduce the life of the battery.

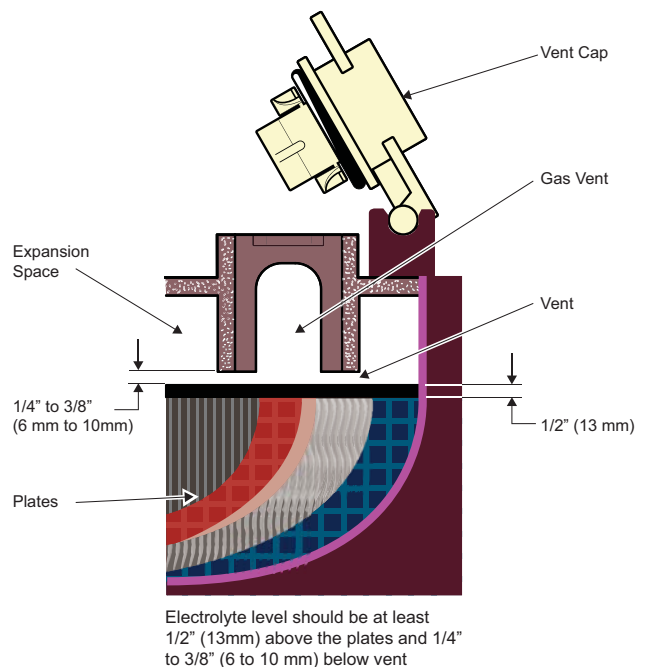

Fig. 22 Correct Electrolyte Level

Over the life of the battery, a considerable amount of water is consumed. It is important that the water used be pure and free of contaminants that could reduce the life of the battery by reducing the chemical reaction. The water must be distilled or purified by an efficient filtration system. Water that is not distilled should be analyzed and, if required, filtration installed to permit the water to meet the requirements of the water purity table (Ref. Fig. 23).

Even if the water is colorless, odorless, tasteless and fit for drinking, the water should be analyzed to see that it does not exceed the impurity levels specified in the table.

OPERATION AND SERVICE INFORMATION

Read all of manual to become familiar with this vehicle. Pay attention to all NOTICES, CAUTIONS, WARNINGS and DANGERS.

Impurity	Parts Per Million
Color	Clear
Suspended	Trace
Total Solids	100
Calcium & Magnesium Oxides	40
Iron	5
Ammonia	8
Organic & Volatile Matter	50
Nitrites	5
Nitrates	10
Chloride	5

Fig. 23 Water Purity Table

Automatic watering devices such as the one included in the Battery Maintenance Kit (P/N 25587-G01) can be used with an approved water source. These watering devices are accurate, easy to use and allow for rapid filling. They also maintain the correct electrolyte level within the battery cells.

WATERING GUN SIMILAR TO THE TYPE INCLUDED IN THE E-Z-GO BATTERY MAINTENANCE KIT

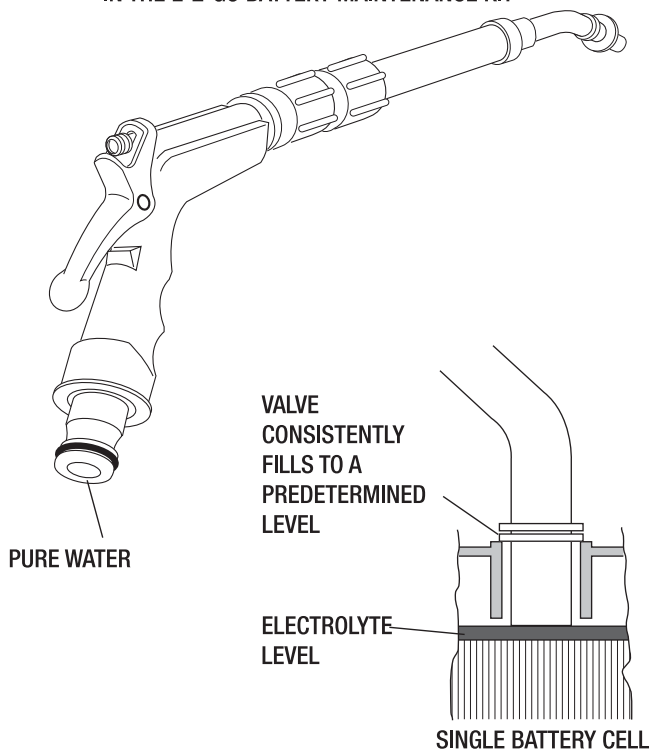

Fig. 24 Automatic Watering Gun

NOTICE

The watering device should only be used if the electrolyte level is less than 1/2" (13 mm) above top of plates.

WARNING

The electrolyte in a storage battery is an acid solution which can cause severe burns to the skin and eyes. Treat all electrolyte spills to the body and eyes with extended flushing with clear water. Contact a physician immediately.



Always wear a safety shield or approved safety goggles when adding water or charging batteries.

Any electrolyte spills should be neutralized with a solution of 1/4 cup (60 ml) sodium bicarbonate (baking soda) dissolved in 1 1/2 gallons (6 liters) of water and flushed with water.

CLEANING BATTERIES

When cleaning the outside of the batteries and terminals, do not use a water hose without first spraying the batteries with a solution of baking soda (sodium bicarbonate) and water to neutralize any acid deposits. Use of a water hose without first neutralizing the acid will move the acid from the top of the batteries to another area of the vehicle or storage facility, where it will attack the metal structure or the concrete/asphalt floor. After hosing down the batteries, a residue will be left on the batteries which is conductive and will contribute to the discharge of the batteries.

CAUTION

To prevent battery damage, be sure that all battery caps are tightly installed.

The correct cleaning technique is to spray the top and sides of the batteries with a solution of baking soda and water. This solution is best applied with a garden-type sprayer equipped with a non-metallic spray wand. The solution should consist of 1/4 cup (60 ml) of baking soda mixed with 1 1/2 gallons (6 liters) of clear water. In addition to the batteries special attention should be paid to metallic components adjacent to the batteries, these should also be sprayed with the baking soda solution.

OPERATION AND SERVICE INFORMATION

Read all of manual to become familiar with this vehicle. Pay attention to all NOTICES, CAUTIONS, WARNINGS and DANGERS.

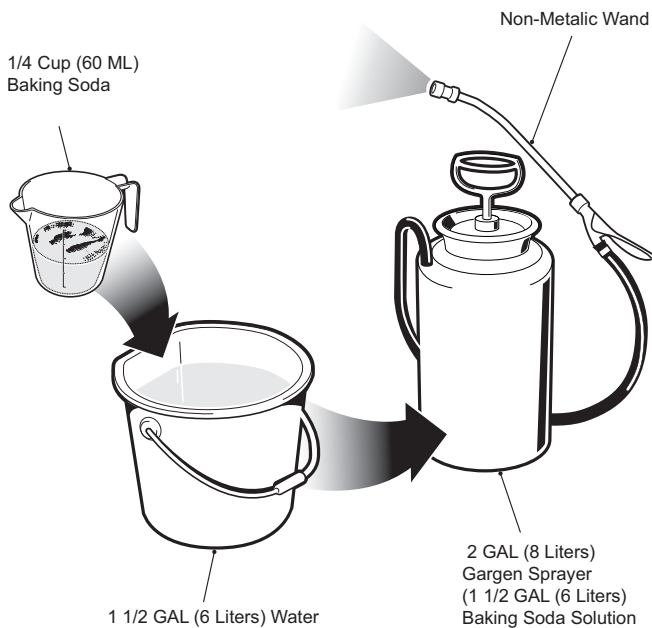

Fig. 25 Preparing Acid Neutralizing Solution

Allow the solution to set for at least three minutes; use a soft bristle brush or cloth to wipe the tops of the batteries in order to remove any residue that could cause the self-discharge of the battery. Rinse the entire area with low pressure clear water. All of the items required for complete battery cleaning and watering are contained in the Battery Maintenance Kit (P/N 25587-G01).

Cleaning should take place once a month or more often under extreme conditions. After batteries are clean and dry, the terminals should be coated with a commercially available protectant. **Aerosol containers of battery terminal protectant must be used with extreme care. Insulate the metal container to prevent the can from contacting the battery terminals.**

BATTERY REMOVAL & INSTALLATION

Tool List	Qty.
Insulated Wrench, 9/16"	1
Socket, 1/2" Deep-well	1
Socket, 9/16"	1
Ratchet	1
Battery Carrier Strap	2
Torque Wrench, in. lbs.....	1
Portable Lifting Device	1
Torx Bit, 50 IP	1

WARNING

SAFETY FIRST

BEND KNEES WHEN LIFTING

Batteries are heavy. Use proper lifting techniques when moving them. Always lift the battery with a commercially available battery lifting device. Use care not to tip batteries when removing or installing them; spilled electrolyte can cause burns and damage.

NOTICE

In the following text, there are references to removing/installing bolts, etc. Additional hardware (nuts, washers, etc.) that is removed must always be installed in its original position unless otherwise specified. Non-specified torques are as shown in the torque specifications (See Fig. 20).

1. Turn vehicle key to the off position and remove the key.
2. Using an insulated wrench, disconnect the main negative (-), BL-, battery cable.
3. Using an insulated wrench, disconnect the main positive (+), BL+, battery cable.
4. Using an insulated wrench, disconnect and remove all other wires connected to the batteries.
5. Remove the two Pan Head Torx screws, (one on each side) from the Battery Strap.
6. Remove the battery hold down and the battery strap by loosening all three hex nuts until they are at the end of the J-bolt and unhooking the J-bolts from the battery tray. When removing the J-bolts from between the batteries it may help to tilt the battery to the outside of the car to release the pressure on the J-bolt.
7. Remove the batteries using commercially available battery carrier straps (2 per battery) and a portable lifting device. Remove the three front batteries (1, 2, & 3) one at a time; then using the carrier straps tilt the last battery (4) to the front of the vehicle just enough to clear the rear body and using the portable lifting device lift the battery up and out of the vehicle.
8. Check the area surrounding the battery tray for corrosion. If any corrosion is found, it should be immediately removed with a putty knife and a wire brush (for metal surfaces) or a plastic bristle brush (for plastic surfaces). The area should be washed with a solution of baking soda and water and dried thoroughly. All

OPERATION AND SERVICE INFORMATION

Read all of manual to become familiar with this vehicle. Pay attention to all **NOTICES, CAUTIONS, WARNINGS and DANGERS.**

metal surfaces that have been cleaned must be primed and painted with a corrosion resistant paint.

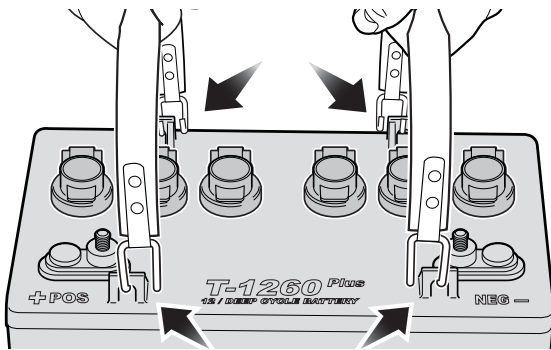

Fig. 26 Battery Removal

- Replace the batteries, using the portable lifting device, starting with the battery located at the back of the battery tray (4), making sure that it is positioned as shown.

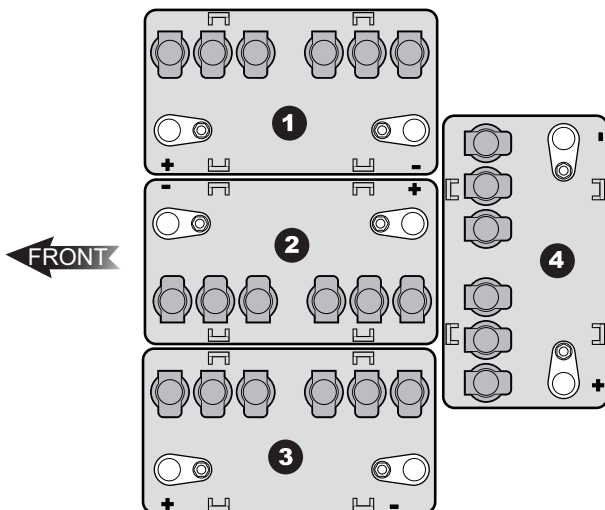

Fig. 27 Battery Placement & Orientation

- With the J-bolts in the battery hold-down and held in place by the hex nuts on the end of the threaded portion; carefully position the battery hold-down and the battery strap, guiding the J-bolts between the batteries (it may be necessary to tip the batteries slightly) and into the slots in the battery tray. Tighten the hex nuts on the J-bolts making sure that the J-bolts are securely hooked in the battery tray. Tighten the J-bolt hex nuts to 62 - 80 in. lbs. (7 - 9 Nm) torque.
- Install the two Pan Head Torx drive screws through the ends of the battery strap into the holes on the vehicle frame and tighten them to 80 - 97 in. lbs. (9 - 11 Nm) torque.

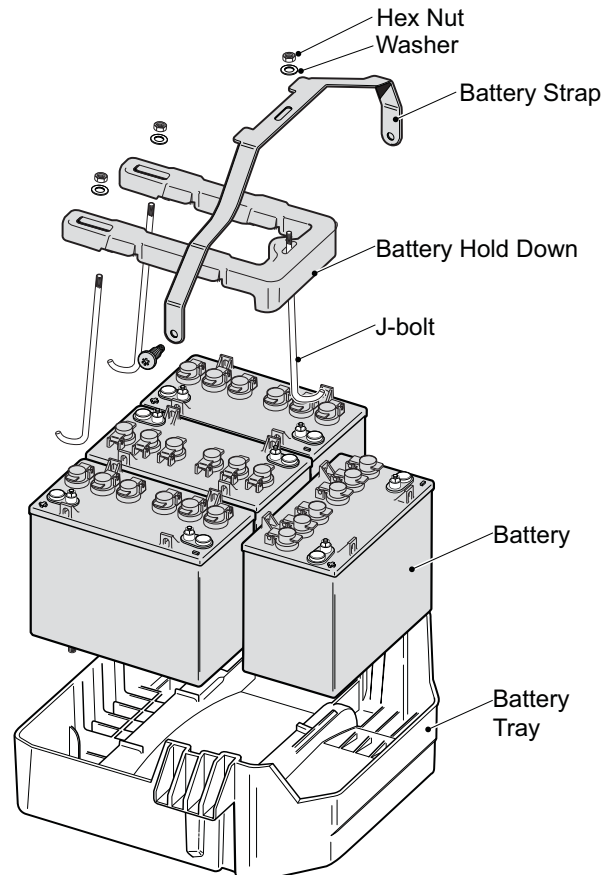

Fig. 28 Battery Components

- Inspect all wires and terminals and clean any corrosion from the battery terminals or wire terminals with a solution of baking soda and water, using a wire brush to completely remove corrosion if required.
- Carefully replace the wires on the battery terminals as shown (Ref. Fig. 29). Make sure to reconnect the main negative (-) battery cable, BL-, from the controller last.
- Tighten all battery terminal hardware to 98 - 105 in. lbs. (11 - 12 Nm) torque.
- Protect the battery terminals and battery cable terminals with a commercially available protective coating.

WARNING

To prevent battery explosion that could result in severe personal injury or death, extreme care must be used with aerosol containers of battery terminal protectant. Insulate the metal container to prevent the metal can from contacting battery terminals which could result in an explosion.

OPERATION AND SERVICE INFORMATION

Read all of manual to become familiar with this vehicle. Pay attention to all **NOTICES, CAUTIONS, WARNINGS and DANGERS.**

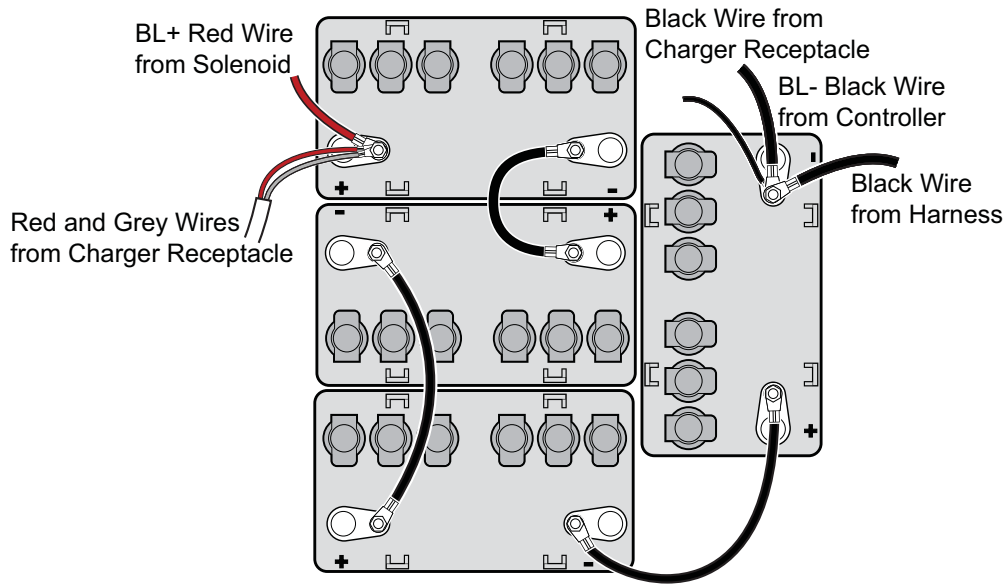

Fig. 29 Battery Connections

PROLONGED STORAGE



CAUTION

Battery charger, controller and other electronic devices need to be disconnected since they will contribute to the premature discharge of batteries.

NOTICE

The 'RUN/TOW' switch, located under the passenger seat is set to 'RUN/STORAGE' c (P) (on European Models) position for long term storage of the vehicle to avoid draining of the batteries.

During periods of storage, the batteries will need attention to keep them maintained and prevent discharge.

In high temperatures the chemical reaction is faster, while low temperatures cause the chemical reaction to slow down. A vehicle that is stored at 90° F (32° C) will lose .002 of specific gravity each day. If a fully charged battery has a specific gravity of 1.275, and the battery is allowed to sit unused, it will become partially discharged. When it reaches 1.240, which it will do in less than twenty days, it should be recharged. If a battery is left in a discharged state, sulfating takes place on and within the plates. This condition is not reversible and will cause permanent damage to the battery. In order to prevent damage, the battery should be recharged. A hydrometer (P/N 50900-G1) can be used to determine the specific gravity and therefore the state of charge of a battery.

In winter conditions, the battery must be fully charged to prevent the possibility of freezing. A fully charged battery will not freeze in temperatures above -75° F (-60° C). Although the chemical reaction is slowed in cold temperatures, the battery must be stored fully charged, and disconnected from any circuit that could discharge the battery. For portable chargers, disconnect the charging plug from the vehicle receptacle. For on-board chargers, disconnect the charging harness from the batteries. The batteries must be cleaned and all deposits neutralized and removed from the battery case to prevent self discharge. The batteries should be tested or recharged at thirty day minimum intervals.

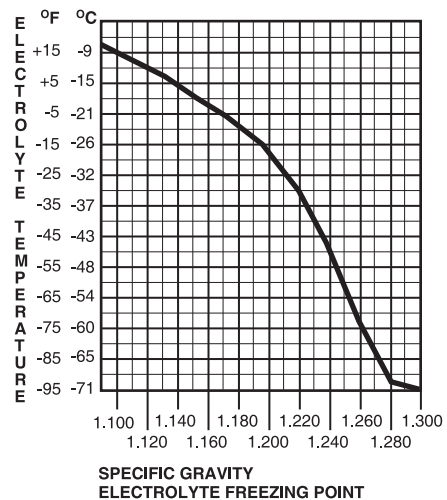

Fig. 30 Freezing Point of Electrolyte

OPERATION AND SERVICE INFORMATION

Read all of manual to become familiar with this vehicle. Pay attention to all **NOTICES, CAUTIONS, WARNINGS and DANGERS.**

BATTERY CHARGING

The battery charger is designed to fully charge the battery set. If the batteries are severely deep cycled, some automatic battery chargers contain an electronic module that may not activate and the battery charger will not function. Automatic chargers will determine the correct duration of charge to the battery set and will shut off when the battery set is fully charged. Always refer to the instructions of the specific charger used.

Before charging, the following should be observed:



CAUTION

Do not overfill batteries. The charging cycle will expel electrolyte and result in component damage.

- The electrolyte level in all cells must be at the recommended level and cover the plates.
- The charging must take place in an area that is well ventilated and capable of removing the hydrogen gas that is generated by the charging process. A **minimum** of five air exchanges per hour is recommended.
- The charging connector components must be in good condition and free from dirt or debris.
- The charger connector must be fully inserted into the vehicle receptacle.
- The charger connector/cord set is protected from damage and is located in an area to prevent injury that may result from personnel running over or tripping over the cord set.
- The charger is automatically turned off during the connect/disconnect cycle and therefore no electrical arc is generated at the DC plug/receptacle contacts.

NOTICE

In **some** portable chargers, there will be a rattle present in the body of the charger DC plug. This rattle is caused by an internal magnet contained within the charger plug. The magnet is part of the interlock system that prevents the vehicle from being driven when the charger plug is inserted in the vehicle charging receptacle.

TROUBLESHOOTING

In general, troubleshooting will be done for two distinct reasons. First, a battery that performs poorly and is outside of the manufacturer's specification should be identified in order to replace it under the terms of the manufacturer's warranty. Different manufacturers have different requirements. Consult the battery manufacturer or the manufacturer's representative for specific requirements.

The second reason is to determine why a particular vehicle does not perform adequately. Performance problems may result in a vehicle that runs slowly or in a vehicle that is unable to operate for the time required.

A new battery must **mature** before it will develop its maximum capacity. Maturing may take up to 100 charge/discharge cycles. After the maturing phase, the older a battery gets, the lower the capacity. The only way to determine the capacity of a battery is to perform a load test using a discharge machine following manufacturer's recommendations.

A cost effective way to identify a poorly performing battery is to use a hydrometer to identify a battery in a set with a lower than normal specific gravity. Once the particular cell or cells that are the problem are identified, the suspect battery can be removed and replaced. At this point there is nothing that can be done to salvage the battery; however, the individual battery should be replaced with a good battery of the same brand, type and approximate age.

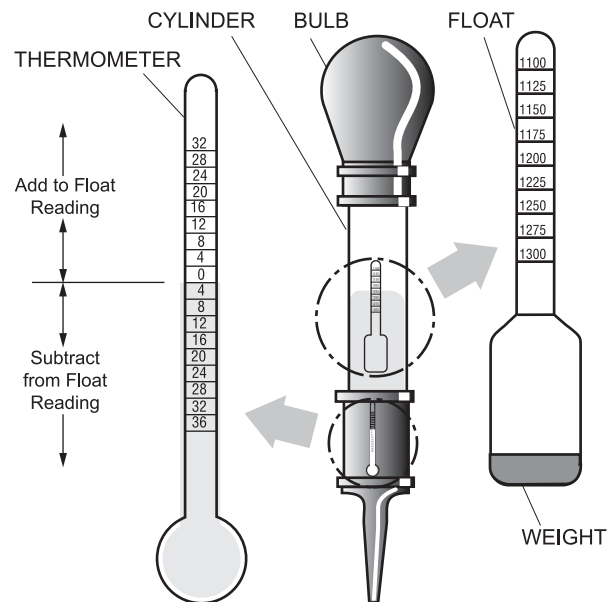

Fig. 31 Hydrometer

HYDROMETER

A hydrometer is used to test the state of charge of a battery cell. This is performed by measuring the density of the electrolyte, which is accomplished by measuring the specific gravity of the electrolyte. The greater the concentration of sulfuric acid, the more dense the electrolyte becomes. The higher the density, the higher the state of charge.

OPERATION AND SERVICE INFORMATION

Read all of manual to become familiar with this vehicle. Pay attention to all **NOTICES, CAUTIONS, WARNINGS and DANGERS.**

WARNING

To prevent battery explosion that could result in severe personal injury or death, never insert a metal thermometer into a battery. Use a hydrometer with a built in thermometer that is designed for testing batteries.

Specific gravity is the measurement of a liquid that is compared to a baseline. The baseline is water which is assigned a base number of 1.000. The concentration of sulfuric acid to water in a new golf car battery is 1.280 which means that the electrolyte weighs 1.280 times the weight of the same volume of water. A fully charged battery will test at 1.275 - 1.280 while a discharged battery will read in the 1.140 range.

NOTICE

Do not perform a hydrometer test on a battery that has just been watered. The battery must go through at least one charge and discharge cycle in order to permit the water to adequately mix with the electrolyte.

The temperature of the **electrolyte** is important since the hydrometer reading must be corrected to 80° F (27° C). High quality hydrometers are equipped with an internal thermometer that will measure the temperature of the electrolyte and will include a conversion scale to correct the float reading. It is important to recognize that the electrolyte temperature is significantly different from the ambient temperature if the vehicle has been operated.

USING A HYDROMETER

1. Draw electrolyte into the hydrometer several times to permit the thermometer to adjust to the electrolyte temperature and note the reading. Examine the color of the electrolyte. A brown or gray coloration indicates a problem with the battery and is a sign that the battery is nearing the end of its life.
2. Draw the minimum quantity of electrolyte into the hydrometer to permit the float to float freely without contacting the top or bottom of the cylinder.
3. Hold the hydrometer in a vertical position at eye level and note the reading where the electrolyte meets the scale on the float.
4. Add or subtract four points (.004) to the reading for every 10° F (6° C) the electrolyte temperature is above or below 80° F (27° C). Adjust the reading to conform with the electrolyte temperature, e.g., if the reading indicates a specific gravity of 1.250 and the electrolyte

temperature is 90° F (32° C), **add** four points (.004) to the 1.250 which gives a corrected reading of 1.254. Similarly if the temperature was 70° F (21° C), **subtract** four points (.004) from the 1.250 to give a corrected reading of 1.246.

5. Test each cell and note the readings (corrected to 80° F or 27° C). A variation of fifty points between any two cell readings (example 1.250 - 1.200) indicates a problem with the low reading cell(s).

As a battery ages the specific gravity of the electrolyte will decrease at full charge. This is not a reason to replace the battery providing all cells are within fifty points of each other.

Since the hydrometer test is in response to a vehicle exhibiting a performance problem, the vehicle should be recharged and the test repeated. If the results indicate a weak cell, the battery or batteries should be removed and replaced with a good battery of the same brand, type and approximate age.

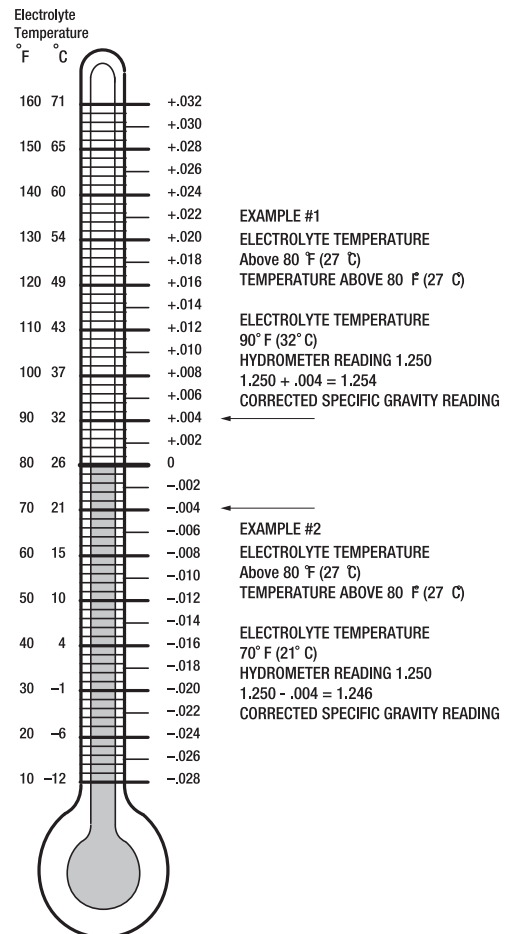

Fig. 32 Hydrometer Temperature Correction

GENERAL SPECIFICATIONS

GENERAL SPECIFICATIONS

RXV ELECTRIC - FLEET VEHICLE SPECIFICATIONS

BATTERIES	Four 12 Volt deep cycle (70 minute minimum, 140 Amp-Hour discharge rate)
SPEED CONTROLLER	Solid state, 230 Amp capacity
MOTOR	3 phase AC induction
TRANSAXLE	16.99:1 Reverse helical geared with input pinion splined to the motor shaft
BRAKES	Motor brake controlled by the speed control unit and service brake pedal
PARKING BRAKE	Automatic parking brake function
FRONT SUSPENSION	Coil springs over hydraulic shock absorbers
REAR SUSPENSION	Leaf springs with hydraulic shock absorbers
STEERING	Single reduction rack & pinion
STEERING WHEEL	Dual handgrips, scorecard holder & pencil holder
SEATING	Foam cushion with vinyl cover and hip restraints/hand holds
SEATING CAPACITY	Operator & 1 passenger
TOTAL LOAD CAPACITY	800 lbs. (360 kg) including operator, passenger, accessories & cargo
SPEED	14 mph (23 kph) in forward on flat ground
CHASSIS	Welded tubular steel, powder coated (DuraShield™)
BODY	Flexible, Impact resistant, Injection Molded TPO (Thermoplastic Polyolefin) with Base Coat / Clear Coat
STANDARD COLORS	Ivory & Forest Green
DASH PANEL	Scuff resistant plastic with 4 drink holders & storage for balls & tees
TIRES	18 x 8.5 - 8 (4 ply rated)**
TIRE PRESSURE	18 - 22 psi (124 - 152 kPa)**
GROUND CLEARANCE	4.5" (11.4 cm) at differential
WEIGHT	571 lbs (259 kg) without batteries
OPERATING CONTROLS & INSTRUMENTATION	Removable key, 'deadman' accelerator control, direction selector, audible reverse warning, state of charge meter
BATTERY CHARGER	Powerwise QE™ 48V, 110 - 120 VAC, fully automatic, line compensating, 13 Amp DC output at 48 Volts, 9.5 Amps input, 60 Hz anti-drive away charger/ vehicle interlock, UL Listed, CSA Certified
NOISE VIBRATION, WBV VIBRATION, HAV	Sound pressure; continued A-weighted equal to 68 db(A) The highest RMS value of weighted acceleration is: 1.15 m/s ² The highest RMS value of weighted acceleration is: less than 2.5 m/s ² The uncertainty of measurement is 0.2 m/s ²

** DO NOT use low inflation pressure tires on any E-Z-GO vehicle. DO NOT use any tire which has a recommended inflation pressure less than the inflation pressure recommended in the Owner's Guide.

RXV ELECTRIC - FREEDOM VEHICLE SPECIFICATIONS

BATTERIES	Four 12 Volt deep cycle (70 minute minimum, 140 Amp-Hour discharge rate)
SPEED CONTROLLER	Solid state, 230 Amp capacity
MOTOR	3 phase AC induction
TRANSAXLE	16.99:1 Reverse helical geared with input pinion splined to the motor shaft
BRAKES	Motor brake controlled by the speed control unit and service brake pedal
PARKING BRAKE	Automatic parking brake function
FRONT SUSPENSION	Coil springs over hydraulic shock absorbers
REAR SUSPENSION	Leaf springs with hydraulic shock absorbers
STEERING	Single reduction rack & pinion
STEERING WHEEL	Dual handgrips, scorecard holder & pencil holder
SEATING	Foam cushion with vinyl cover and hip restraints/hand holds
SEATING CAPACITY	Operator & 1 passenger
TOTAL LOAD CAPACITY	800 lbs. (360 kg) including operator, passenger, accessories & cargo
SPEED	19 mph (31 kph) in forward on flat ground
CHASSIS	Welded tubular steel, powder coated (DuraShield™)
BODY	Flexible, Impact resistant, Injection Molded TPO (Thermoplastic Polyolefin) with Base Coat / Clear Coat
STANDARD COLORS	Ivory & Forest Green
DASH PANEL	Scuff resistant plastic with 4 drink holders & storage for balls & tees
TIRES	18 x 8.5 - 8 (4 ply rated)**
TIRE PRESSURE	18 - 22 psi (124 - 152 kPa)**
GROUND CLEARANCE	4.5" (11.4 cm) at differential
WEIGHT	582 lbs (264 kg) without batteries
OPERATING CONTROLS & INSTRUMENTATION	Removable key, 'deadman' accelerator control, direction selector, audible reverse warning, horn
LIGHTS	Head lights, tail lights, brake lights
BATTERY CHARGER	Powerwise QE™ 48V, 110 - 120 VAC, fully automatic, line compensating, 13 Amp DC output at 48 Volts, 9.5 Amps input, 60 Hz anti-drive away charger/ vehicle interlock, UL Listed, CSA Certified
NOISE VIBRATION, WBV VIBRATION, HAV	Sound pressure; continued A-weighted equal to 68 db(A) The highest RMS value of weighted acceleration is: 1.15 m/s ² The highest RMS value of weighted acceleration is: less than 2.5 m/s ² The uncertainty of measurement is 0.2 m/s ²

** DO NOT use low inflation pressure tires on any E-Z-GO vehicle. DO NOT use any tire which has a recommended inflation pressure less than the inflation pressure recommended in the Owner's Guide.

GENERAL SPECIFICATIONS

RXV ELECTRIC - SHUTTLE 2 + 2 VEHICLE SPECIFICATIONS

BATTERIES	Four 12 Volt deep cycle (70 minute minimum, 140 Amp-Hour discharge rate)
SPEED CONTROLLER	Solid state, 230 Amp capacity
MOTOR	3 phase AC induction
TRANSAXLE	16.99:1 Reverse helical geared with input pinion splined to the motor shaft
BRAKES	Motor brake controlled by the speed control unit and service brake pedal
PARKING BRAKE	Automatic parking brake function
FRONT SUSPENSION	Coil springs over hydraulic shock absorbers
REAR SUSPENSION	Leaf springs with hydraulic shock absorbers
STEERING	Single reduction rack & pinion
STEERING WHEEL	Dual handgrips, scorecard holder & pencil holder
SEATING	Foam cushion with vinyl cover and hip restraints/hand holds
SEATING CAPACITY	Operator & 3 passenger
TOTAL LOAD CAPACITY	700 lbs. (318 kg) including operator, passenger, accessories & cargo
SPEED	14 - 17.5 mph (23 - 28.2 kph) in forward on flat ground
CHASSIS	Welded tubular steel, powder coated (DuraShield™)
BODY	Flexible, Impact resistant, Injection Molded TPO (Thermoplastic Polyolefin) with Base Coat / Clear Coat
STANDARD COLORS	Ivory & Forest Green
DASH PANEL	Scuff resistant plastic with 4 drink holders & storage for balls & tees
TIRES	18 x 8.5 - 8 (4 ply rated)**
TIRE PRESSURE	18 - 22 psi (124 - 152 kPa)**
GROUND CLEARANCE	4.5 inches (11.4 cm) at differential
WEIGHT	643 lbs (292 kg) without batteries
OPERATING CONTROLS & INSTRUMENTATION	Removable key, 'deadman' accelerator control, direction selector, audible reverse warning, horn
LIGHTS	Head lights, tail lights, brake lights
BATTERY CHARGER	Powerwise QE™ 48V, 110 - 120 VAC, fully automatic, line compensating, 13 Amp DC output at 48 Volts, 9.5 Amps input, 60 Hz anti-drive away charger/ vehicle interlock, UL Listed, CSA Certified
NOISE VIBRATION, WBV VIBRATION, HAV	Sound pressure; continued A-weighted equal to 68 db(A) The highest RMS value of weighted acceleration is: 1.15 m/s ² The highest RMS value of weighted acceleration is: less than 2.5 m/s ² The uncertainty of measurement is 0.2 m/s ²

** DO NOT use low inflation pressure tires on any E-Z-GO vehicle. DO NOT use any tire which has a recommended inflation pressure less than the inflation pressure recommended in the Owner's Guide.

GENERAL SPECIFICATIONS

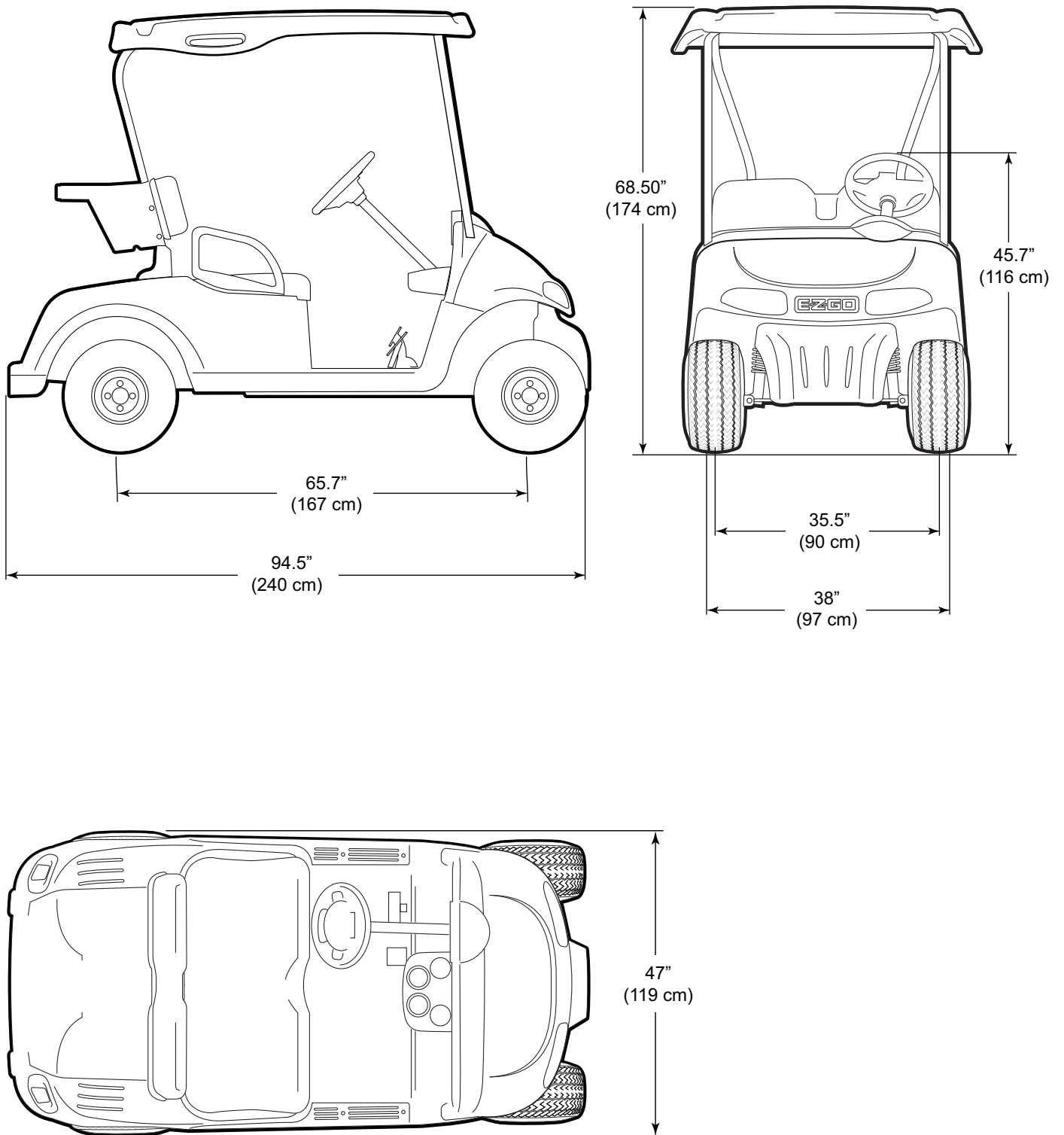

Fig. 31 Fleet & Freedom Vehicle Dimensions

GENERAL SPECIFICATIONS

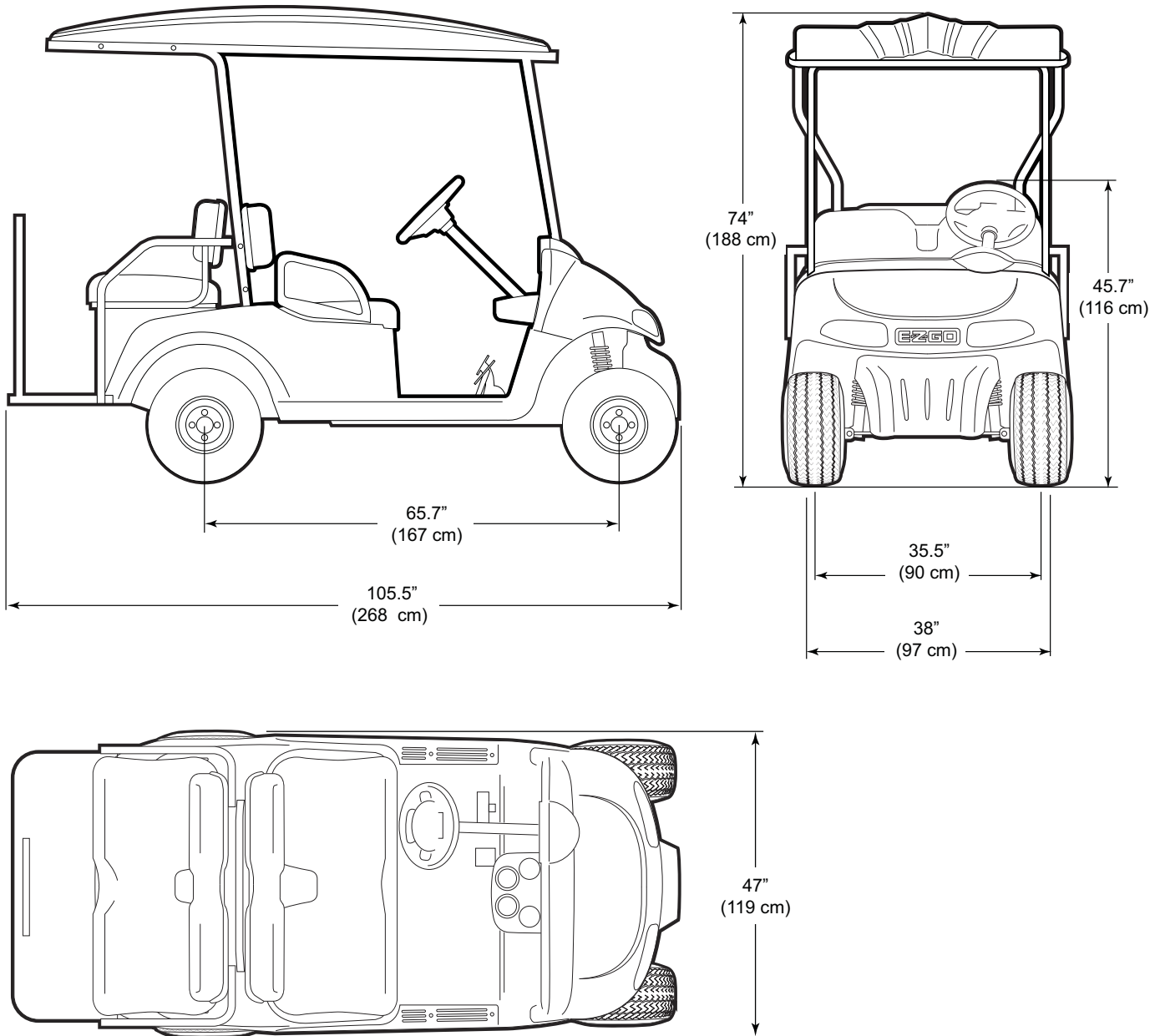
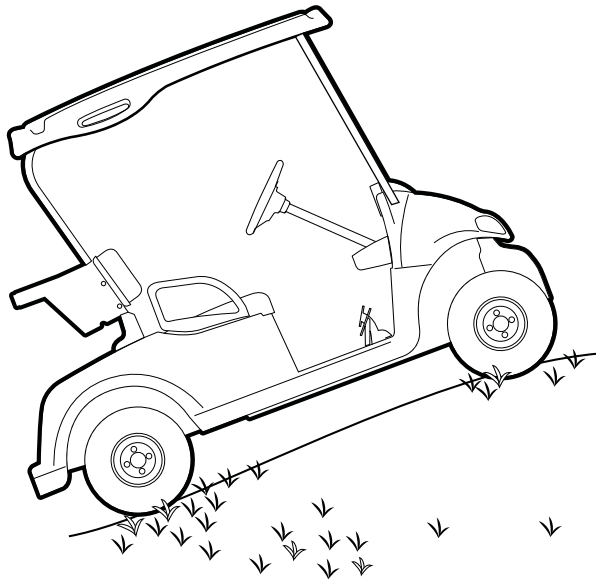
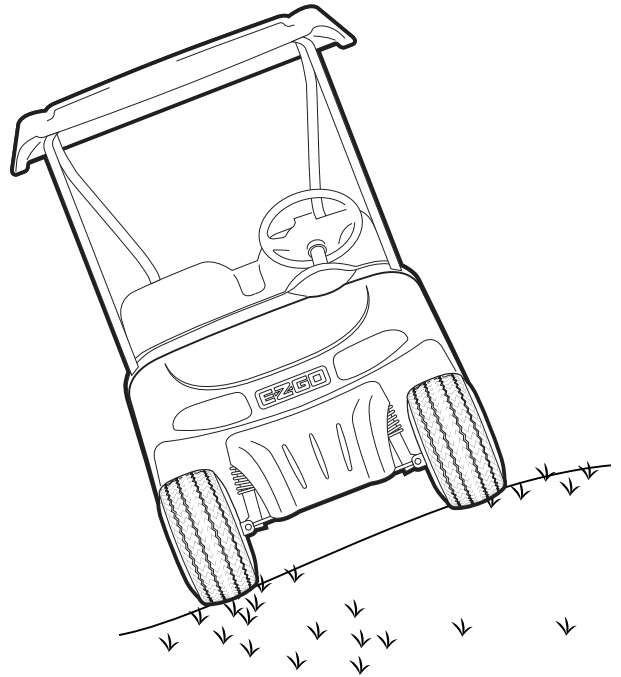

Fig. 31 Shuttle 2 + 2 Vehicle Dimensions



RECOMMENDED MAX RAMP
25% GRADE OR 14° MAX



RECOMMENDED MAX SIDE TILT
25% GRADE OR 14° MAX

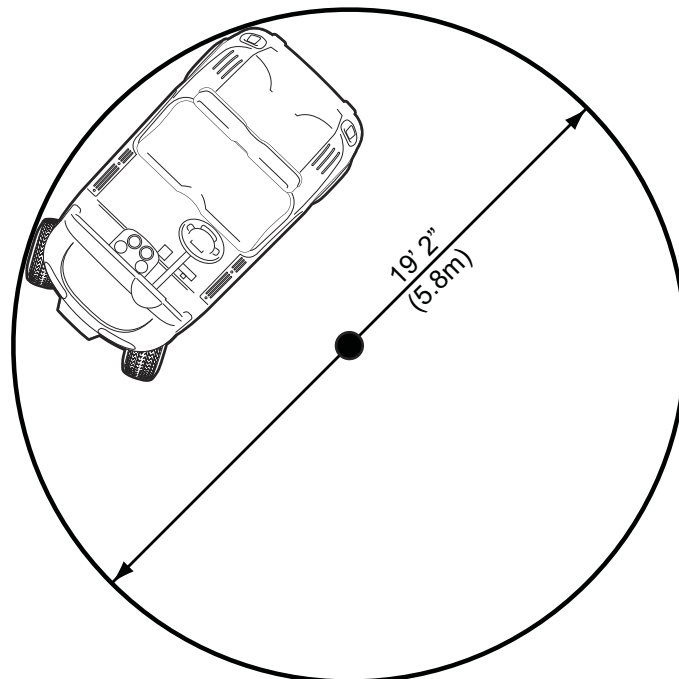

Fig. 32 Vehicle Incline Specifications and Turning Diameter

GENERAL SPECIFICATIONS

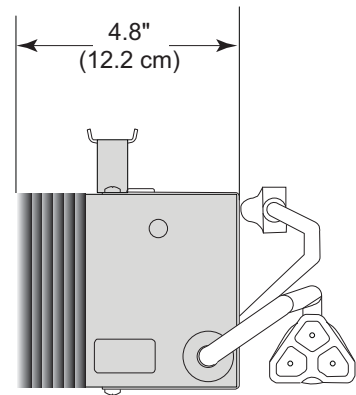
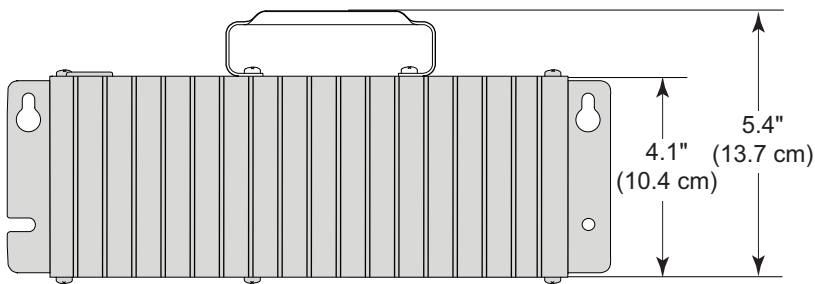
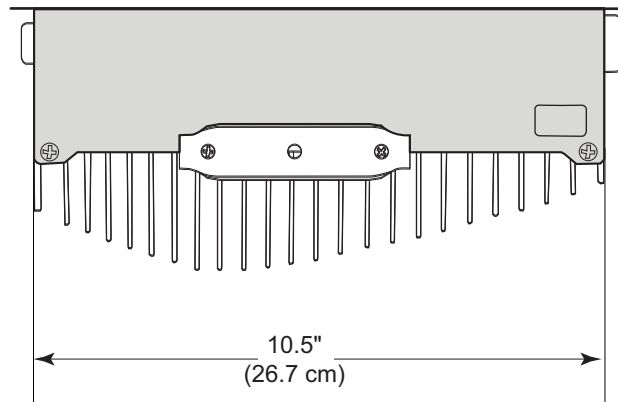
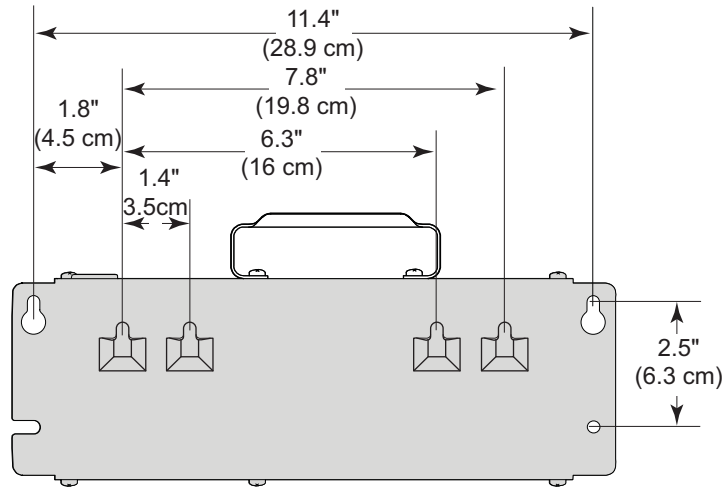

Fig. 33 Powerwise QE 48V Charger

**DECLARATION OF CONFORMITY
(EUROPE ONLY)**

DECLARATION OF CONFORMITY

**DECLARATION OF CONFORMITY - ДЕКЛАРАЦИЯ ЗА СЪОТВЕТСТВИЕ - PROHLÁŠENÍ O SHODĚ -
 ÖVERENSSTEMMELSESERKLÄRING - CONFORMITEITSVERKLARING - VASTAVUSDEKLARATSIOON -
 VAATIMUSTENMUKAISUUSVAKUUTUS - DECLARATION DE CONFORMITE - KONFORMITÄTSEKTLÄRUNG - ΔΗΛΩΣΗ
 ΣΥΜΜΟΡΦΩΣΗΣ - MEGFELELŐSÉGI NYILATKOZAT - DICHIARAZIONE DI CONFORMITÀ - ATBILSTÍBAS DEKLARÁCIJA -
 ATITIKTIES DEKLARACIJA - DIKJARAZZJONI TAL-KONFORMITÀ - DEKLARACJA ZGODNOŚCI - DECLARAÇÃO DE
 CONFORMIDADE - DECLARAȚIE DE CONFORMITATE - VYHLÁSENIE O ZHODE - IZJAVA O SKLADNOSTI - DECLARACIÓN DE
 CONFORMIDAD - DEKLARATION OM ÖVERENSSTÄMMELSE - SAMRÆMISYFIRLÝSING - KONFORMITETSEKTLÄRING**

Business name and full address of the manufacturer • Το πρόσωπο και η πλήρης διεύθυνση του παραγωγού • Obchodní jméno a plná adresa výrobce • Producentens firmanavn og fulde adresse • Bedrijfsnaam en volledige adres van de fabrikant • Toetja äri nimi ja täielik aadress • Valmistajan toimintimi ja täydellinen osoite • Nom commercial et adresse complète du fabricant • Firmennamen und vollständige Adresse des Herstellers • Εταιρική και τοπογραφική διεύθυνση κατασκευαστή • A gyártó üzleti neve és teljes címe • Ragione sociale e indirizzo completo del fabbricante • Uz pŕemuma nosaukums un pilna ražotāja adrese • Verslo pavadinimas ir pilnas gamintojo adresas • Isem kummeržali u indirizz sħiħ tal-fabbrikant • Nazwa firmy i pełny adres producenta • Nome da empresa e endereço completo do fabricante • Denumirea comercială și adresa completă a producătorului • Obchodný názov a úplná adresa výrobcu • Naziv podjetja in polni naslov proizvajalca • Nombre de la empresa y dirección completa del fabricante • Tilverkarens företagsnamn och kompletta adress • Fyrirtækisheiti og fullt heimilisfang framleiðanda • Firmanavn og full adresse for produsenten	E-Z-GO Division of Textron Inc, 1451 Marvin Griffin Road Augusta, GA 30906 USA
Product Code • Код на продукта • Kód výrobku • Produktkode • Productcode • Toote kood • Tuotekoodi • Code produit • Produktcode • Κωδικός προϊόντος • Termékkód • Codice prodotto • Produkta kods • Produkto kodas • Kodičiči tal-Prodott • Kod produktu • Código do Produto • Cod produs • Kód výrobku • Oznaka proizvoda • Código de producto • Produktkod • Vörunúmer • Produktkode	606600, 606602, 606604, 609184 When Fitted With CE Kit 614081
Machine Name • Наименование на машината • Název stroje • Maskinnavn • Machinenamen • Masina nimi • Laitteen nimi • Nom de la machine • Maschinenbezeichnung • Ονομασία μηχανήματος • Géplén • Denominazione della macchina • Iek ārtas nosaukums • Mašinos pavadinimas • Isem tal-Magna • Nazwa urzadzenia • Nome da Máquina • Numele echipamentului • Název stroja • Naziv stroja • Nombre de la máquina • Maskinens namn • Heiti tækis • Maskinnavn	RXV golf car (electric models)
Designation • Предназначение • Označení • Betegnelse • Benaming • Nimetus • Tyypimerkintä • Pažymėjimas • Bezeichnung • Χαρακτηρισμός • Megnevezés • Funzione • Apzīmējums • Lithuanian • Denominazzjoni • Oznaczenie • Designação • Specificație • Označenie • Namen stroja • Descripción • Beteckning • Merking • Konstruksjon	Golf Car
Serial Number • Серийн номер • Sériové číslo • Seriennummer • Seriennummer • Seriennummer • Valmistusnumero • Numéro de série • Seriennummer • Σειριακός αριθμός • Sorozatszám • Numero di serie • Sérijas numurs • Serijos numeris • Numru Serjali • Numer seryjny • Número de Série • Număr de serie • Sériové číslo • Serijska številka • Número de serie • Seriennummer • Raðnúmer • Seriennummer	5104185 to 5200000
Conforms to Directives • В съответствие с директивите • Splňuje podmínky směrnice • Er i overensstemmelse med direktiver • Voldoet aan de richtlijnen • Vastab direktiividele • Direktiivien mukainen • Conforme aux directives • Entspricht Richtlinien • Ακολουθείτε πιστά τις Οδηγίες • Megfelel az irányelveknek • Conforme alle Direttive • Atbilst direktívām • Atitinka direktyvų reikalavimus • Valutazzjoni tal-Konformità • Dyrektywy związane • Cumpre as Directivas • Respectă Directivele • Je v súlade so smernicami • Skladnost z direktivami • Cumpre con las Directivas • Uppfylder direktiv • Samr æmist tilskipunum • I samsvar med direktiv	2006/42/EC
Conformity Assessment • Оценка за съответствие • Hodnocení plnění podmínek • Överensstemmelsesvurdering • Conformitätsbeurteilung • Vastavushindamine • Vaatimustenmukaisuuden arviointi • Evaluation de conformité • Konformitätsbeurteilung • Διαπίκωση Συμμόρφωσης • Megfelelőség-értékelés • Valutazione della conformità • Atbilstības novērtējums • Atitikties įvertinimas • Livelli tal-Qawwa tal-Foss Imkejjel • Ocena zgodności • Avaliação de Conformidade • Evaluarea conformității • Vyhodnotenie zhodnosti • Ocena skladnosti • Evaluación de conformidad • Bedömning av överensstämmelse • Samr æmistat • Konformitetsvurdering	2006/42/EC Annex II
Harmonised standards used • Използвани хармонизирани стандарти • Použité harmonizované normy • Brugte harmoniserede standarder • Gebruikte geharmoniseerde standaards • Kasutatud ühtlustatud standardid • Käytetyt yhdenmukaistetut standardit • Normes harmonisées utilisées • Angewandte harmonisierte Normen • Εναρμονισμένα πρότυπα που χρησιμοποιήθηκαν • Harmonizált szabványok • Standard armonizzati applicati • Izmantotie saskaņotie standarti • Panaudoti suderinti standartai • Standards armonizzati usati • Normy spóĝne powiazane • Normas harmonizadas usadas • Standardele armonizate utilizate • Použité harmonizované normy • Uporabljeni usklajeni standardi • Estándares armonizados utilizados • Harmoniserade standarder som används	EN 61000-6-2:2005 EN 61000-6-4:2007 EN ISO 5349:1986 EN ISO 11202
Technical standards and specifications used • Използвани технически стандарти и спецификации • Použité technické normy a specifikace • Brugte tekniske standarder og specifikationer • Gebruikte technische standaards en specificaties • Kasutatud tehnilised standardid ja spetsifikatsioonid • Käytetyt tekniset standardit ja eritelmät • Spécifications et normes techniques utilisées • Angewandte technische Normen und Spezifikationen • Τεχνικά πρότυπα και προδιαγραφές που χρησιμοποιήθηκαν • Műszaki szabványok és specifikációk • Standard tecnici e specifiche applicati • Izmantotie tehniskie standarti un specifickācijas • Panaudoti techniniai standartai ir techninė informacija • Standards u specifickazzjonijiet teknički užati • Normy i specyfikacje techniczne powiazane • Normas técnicas e especificações usadas • Standardele tehnice și specificațiile utilizate • Použité technické normy a špecifikácie • Uporabljeni tehnični standardi in specifikacije • Estándares y especificaciones técnicas utilizadas • Tekniska standarder och specifikationer som används • Samr æmdir staðlar sem notaðir eru • Benyttede harmoniserede standarder	ISO 2631-1:1985
The place and date of the declaration • Место и дата на декларацията • Misto a datum prohlášení • Sted og dato for erklæringen • Plaats en datum van de verklaring • Deklaratsiooni väljastamise koht ja kuupäev • Vakuutuksen paikka ja päivämäärä • Lieu et date de la déclaration • Ort und Datum der Erklärung • Τόπος και ημερομηνία δήλωσης • A nyilatkozat kelte (hely és idő) • Luogo e data della dichiarazione • Deklarācijas vieta ir datums • Deklaracijos vieta ir data • Il-post u d-data tad-dikjarazzjoni • Miejsce i data wystawienia deklaracji • Local e data da declaração • Locul și data declarării • Miesto a dátum vyhlášení • Kraj in datum izjave • Lugar y fecha de la declaración • Plats och datum för deklarationen • Tæknistaðlar og tæknilysingar sem notaðar eru • Benyttede tekniske standarder og spesifikasjoner • Staður og dagsetning yfirlýsingar • Sted og dato for erklæringen	E-Z-GO Division of Textron Inc, 1451 Marvin Griffin Road Augusta, GA 30906 USA

DECLARATION OF CONFORMITY

Signature of the person empowered to draw up the declaration on behalf of the manufacturer, holds the technical documentation and is authorised to compile the technical file, and who is established in the Community.

Подпис на човека, упълномощен да състави декларацията от името на производителя, който поддържа техническата документация и е сторириран да изготви техническия файл и е регистриран в общността.

Podpis osoby oprávněné sestavit prohlášení jménem výrobce, držel technickou dokumentaci a osoby oprávněné sestavit technické soubory a založené v rámci Evropského společenství.

Underskrift af personen, der har fuldmagt til at udarbejde erklæringen på vegne af producenten, der er indehaver af dokumentationen og er bemyndiget til at udarbejde den tekniske journal, og som er baseret i nærområdet.

Handtekening van de persoon die bevoegd is de verklaring namens de fabrikant te tekene, de technische documentatie bewaart en bevoegd is om het technische bestand samen te stellen, en die is gevestigd in het Woongebied.

Ühenduse registreeris kantud isiku allkiri, kes on volitatud tootja nimel deklaratsiooni koostama, kes omab tehnilist dokumentatsiooni ja kellel on õigus koostada tehniilise loomik.

Sen henkilön allekirjollus, jolla on valmistajan valtuutus vakuutuksen laadintaan, jolla on hallussaan tekniset asiakirjat, joka on valtuutettu laatimaan tekniset asiakirjat ja joka on sijoittautunut yhteisöön.

Signature de la personne habilitée à rédiger la déclaration au nom du fabricant, à détenir la documentation technique, à compiler les fichiers techniques et qui est implantée dans la Communauté.

Unterschrift der Person, die berechtigt ist, die Erklärung im Namen des Herstellers abzugeben, die die technischen Unterlagen aufbewahrt und berechtigt ist, die technischen Unterlagen zusammenzustellen, und die in der Gemeinschaft niedergelassen ist.

Υπογραφή ατόμου εξουσιοδοτημένου για την σύνταξη της δήλωσης εκ μέρους του κατασκευαστή, ο οποίος κατέχει την τεχνική έκθεση και έχει την εξουσιοδότηση να τακτοποιήσει τον τεχνικό φάκελο και ο οποίος είναι διαρισμένος στην Κοινότητα.

A gyártó nevében meghatalmazott személy, akinek jogában áll módosítani a nyilatkozatot, a műszaki dokumentációt őrizi, engedélyvel rendelkezik a műszaki fájel összerakításához, és aki a közösségen felelősedett személy.

Firma della persona autorizzata a redigere la dichiarazione a nome del fabbricante, in possesso della documentazione tecnica ed autorizzata a costituire il fascicolo tecnico, che deve essere stabilita nella Comunità.

Tās personas paraksts, kura ir pilnvarota deklarācijas sastādīšanai nodotā vārdā, kural ir tehniskā dokumentācija, kura ir pilnvarota sagatavot tehnisko reģistru un kura ir apstiprināta Kopienā.

Asmuo, kuris yra gana žinomas, kuriam gamintojas suteikė įgaliojimus sudaryti šią deklaraciją, ir kuris ją pasirašė, turi visą techninę informaciją ir yra įgalotas sudaryti techninės informacijos dokumentą.

Il-firma tal-persuna awtorizzata li fassal id-dikjarazzjoni fil-em il-fabbrikanti, g handha d-dokumentazzjoni teknika u hija awtorizzata li ikkompila l-fajl tekniku u li hija stabilita fl-Komunita.

Podpis osoby upowaznionej do sporzadzania deklaracji w imieniu producenta, przechowujacej dokumentacje techniczna, upowazniona do stworzenia dokumentacji technicznej oraz wyznaczonej ds. wspolnotowych.

Assinatura da pessoa com poderes para emitir a declaracao em nome do fabricante, que possui a documentacao tecnica, que esta autorizada a compilar o processo tecnico e que esta estabelecida na Comunidade.

Semnatūra persoanei împuternicite să elaboreze declarația în numele producătorului, care deține documentația tehnică, este autorizată să compileze dosarul tehnic și este stabilită în Comunitate.

Podpis osoby poverenej vystavením vyhlásenia v mene výrobcu, ktorá má technickú dokumentáciu a je oprávnená spracovať technické podklady a ktorá je umiestnená v Spoločenstve.

Podpis osobe, pooblašene za izdelavo izjave v imenu proizvajalca, ki ima tehnično dokumentacijo in lahko sestavi spis tehnične dokumentacije, ter ima sedež v Skupnosti.

Firma de la persona responsable de la declaración en nombre del fabricante, que posee la documentación técnica y está autorizada para recopilar el archivo técnico y que está establecido en la Comunidad.

Undertecknas av den som bemyndigad att upprätta deklARATIONEN å tillverkarens vägnar, innehar den tekniska dokumentationen och är bemyndigad att sammansätta den tekniska informationen och som är etablerad i gemenskapen.

Undirskrift aðilans sem hefur umboð til að gera yfirlýsinguna fyrir hönd framleiðandans, hefur undir höndum teknigögnin og hefur leyfi til að taka saman tekniskýrsluna, og er viðurkennður innan evrópska efnahagssvæðisins.

Signaturen til personen som har fuldmagt til at udfærdige erklæringen på vegne af producenten, er i besiddelse af den tekniske dokumentationen, har autorisasjon til å utarbeide den tekniske filen og som har tilhold i EU.

2006/42/EC Annex II 1A: 2
Tim Lansdell
 Technical Director
 20th January 2010
 Ransomes Jacobsen
 Ltd, West Road, Ransomes Europark,
 Ipswich,
 England, IP3 9TT



2006/42/EC Annex II 1A: 10
Ronald L. Otten
 Vice President of Engineering
 E-Z-GO Division of Textron Inc,
 1451 Marvin Griffin Road
 Augusta, GA 30906 USA
 20th January 2010

GB
United Kingdom

BG
Bulgaria

CH
Switzerland

CZ
Czech Republic

DK
Denmark

NL
Netherlands

EE
Estonia

ES
Spain

FI
Finland

FR
France

DE
Germany

GR
Greece

HU
Hungary

IS
Iceland

IT
Italy

LI
Liechtenstein

LV
Latvia

LT
Lithuania

MT
Malta

NO
Norway

PL
Poland

PT
Portugal

RO
Romania

SE
Sweden

SK
Slovakia

SI
Slovenia

NOTICE

Read the following warnings before attempting to operate the vehicle.

WARNING

To prevent personal injury or death, observe the following:

When vehicle is to be left unattended, engage park brake, move direction selector to neutral, turn key to 'OFF' position and remove key.

Drive vehicle only as fast as terrain and safety considerations allow. Consider the terrain and traffic conditions. Consider environmental factors which effect the terrain and the ability to control the vehicle.

Avoid driving fast down hill. Sudden stops or change of direction may result in a loss of control. Use service brake to control speed when traveling down an incline.

Use extra care and reduced speed when driving on poor surfaces, such as loose dirt, wet grass, gravel, etc.

All travel should be directly up or down hills.

Use extra care when driving the vehicle across an incline.

Stay in designated areas and avoid steep slopes. Use the park brake whenever the vehicle is parked.

Keep feet, legs, hands and arms inside vehicle at all times.

Avoid extremely rough terrain.

Check area behind the vehicle before operating in reverse.

Make sure the direction selector is in correct position before attempting to start the vehicle.

Slow down before and during turns. All turns should be executed at reduced speed.

Always bring vehicle to a complete stop before shifting the direction selector.

See GENERAL SPECIFICATIONS for vehicle load and seating capacity.

NOTICE

Read the following text and warnings before attempting to service vehicle.

In any product, components will eventually fail to perform properly as the result of normal use, age, wear or abuse.

It is virtually impossible to anticipate all possible component failures or the manner in which each component may fail.

Be aware that a vehicle requiring repair indicates that the vehicle is no longer functioning as designed and therefore should be considered potentially hazardous. Use extreme care when working on any vehicle. When diagnosing, removing or replacing any components that are not operating correctly, take time to consider the safety of yourself and others around you should the component move unexpectedly.

Some components are heavy, spring loaded, highly corrosive, explosive or may produce high amperage or reach high temperatures. Battery acid and hydrogen gas could result in serious bodily injury to the technician/mechanic and bystanders if not treated with the utmost caution. Be careful not to place hands, face, feet or body in a location that could expose them to injury should an unforeseen situation occur.

Always use the appropriate tools listed in the tool list and wear approved safety equipment.

WARNING

Before working on the vehicle, remove all jewelry (rings, watches, necklaces, etc.)

Be sure no loose clothing or hair can contact moving parts.

Use care not to touch hot objects.

Raise rear of vehicle and support on jack stands before attempting to run or adjust powertrain.

Wear eye protection when working on or around the vehicle. In particular, use care when working around batteries, using solvents or compressed air.

Hydrogen gas is formed when charging batteries. Do not charge batteries without adequate ventilation.

Do not permit open flame or anyone to smoke in an area that is being used for charging batteries. A concentration of 4% hydrogen gas or more is explosive.



A Textron Company

E-Z-GO Division of Textron Inc.,
1451 Marvin Griffin Road, Augusta, Georgia USA 30906-3852

TO CONTACT US...

North America:

**Technical Assistance & Warranty
Service Parts**

Phone: 1-800-774-3946, FAX: 1-800-448-8124

Phone: 1-888-GET-E-Z-GO (1-888-438-3946), FAX: 1-800-752-6175

International:

Phone: 001-706-798-4311, FAX: 001-706-771-4609

Certified ISO 9001 / ISO 14001 by



Copyrighted Material

This manual may not be reproduced in whole or
in part without the express permission of

E-Z-GO Division of Textron, Inc.

Technical Communications Department